

# Bonhams



Modern Design | Art

Los Angeles | April 24, 2019



# Modern Design | Art

Los Angeles | Wednesday April 24, 2019 at 11am

---

## BONHAMS

7601 W. Sunset Boulevard  
Los Angeles CA 90046  
[bonhams.com](http://bonhams.com)

## PREVIEW

### Los Angeles

Friday, April 19,  
10am to 5pm  
Saturday, April 20,  
12pm to 5pm  
Sunday, April 21,  
12pm to 5pm  
Monday, April 22,  
10am to 5pm  
Tuesday, April 23,  
10am to 5pm

**SALE NUMBER:** 25334

Lots 1 - 388

**CATALOG:** \$35

## LOT SYMBOLS

**W** - Oversized lots

**Y** - CITES

## BIDS

+1 (323) 850 7500  
+1 (323) 850 6090 fax

To bid via the internet please visit  
[www.bonhams.com/25334](http://www.bonhams.com/25334)

Please note that telephone bids must be submitted no later than 4pm on the day prior to the auction. New bidders must also provide proof of identity and address when submitting bids. Telephone bidding is only available for lots with a low estimate in excess of \$1000.

Please contact client services with any bidding inquiries.

Please see pages 210 to 213 for bidder information including Conditions of Sale, after-sale collection and shipment.

## INQUIRIES

### Los Angeles

Jason Stein  
Director  
+1 (323) 436 5466  
[jason.stein@bonhams.com](mailto:jason.stein@bonhams.com)

### Katherine Miller

Business Administrator  
+1 (323) 436 5445  
[katherine.miller@bonhams.com](mailto:katherine.miller@bonhams.com)

### New York

Dan Tolson  
Director  
+1 (917) 206 1611  
[dan.tolson@bonhams.com](mailto:dan.tolson@bonhams.com)

### Benjamin Walker

Head of Department  
+1 (212) 710 1306  
[benjamin.walker@bonhams.com](mailto:benjamin.walker@bonhams.com)

## ILLUSTRATIONS

Front Cover: Lot 122  
Back Cover: Lot 95  
Inside front cover: Lot 94  
Inside back cover: Lot 177

## REGISTRATION IMPORTANT NOTICE

Please note that all customers, irrespective of any previous activity with Bonhams, are required to complete the Bidder Registration Form in advance of the sale. The form can be found at the back of every catalogue and on our website at [www.bonhams.com](http://www.bonhams.com) and should be returned by email or post to the specialist department or to the bids department at [bids.us@bonhams.com](mailto:bids.us@bonhams.com)

To bid live online and / or leave internet bids please go to [www.bonhams.com/auctions/25334](http://www.bonhams.com/auctions/25334) and click on the Register to bid link at the top left of the page.



## Bonhams

220 San Bruno Avenue  
San Francisco, California 94103  
© 2019, Bonhams & Butterfields  
Bond No. 57BSBGL0808 Auctioneers  
Corp.; All rights reserved.



1

**GRUEBY FAIENCE COMPANY (FOUNDED 1894)**

Bowl

early 20th century

glazed earthenware, impressed 'GRUEBY POTTERY BOSTON U.S.A.'

in a circle, incised 'CH #y39-1', with paper label

height 6 3/4in (17cm); diameter 9in (22cm)

**\$1,500 - 2,000**

**Provenance:**

Private Collection, Northern California

2

**GRUEBY FAIENCE COMPANY (FOUNDED 1894)**

Bowl

early 20th century

glazed earthenware, impressed 'GRUEBY POTTERY BOSTON U.S.A.'

in a circle, incised ER

height 3 1/2in (8cm); diameter 5 1/4in (13cm)

**\$2,000 - 3,000**

**Provenance:**

Private Collection, Northern California

3

**GRUEBY FAIENCE COMPANY (FOUNDED 1894)**

Vase

early 20th century

glazed earthenware, indistinctly impressed 'GRUEBY POTTERY

BOSTON U.S.A.' in a circle

height 7 1/4in (18cm)

**\$2,000 - 3,000**

**Provenance:**

Private Collection, Northern California



1

2

3

4  
**GRUEBY FAIENCE COMPANY (FOUNDED 1894)**  
Vase  
early 20th century  
glazed earthenware, impressed 'GRUEBY POTTERY BOSTON U.S.A.'  
in a circle, incised 'EK'  
*height 7 1/4in (18cm)*

**\$2,500 - 3,500**

**Provenance:**  
Private Collection, Northern California

5  
**NEWCOMB COLLEGE (1895-1940)**  
Plate  
circa 1913  
decorated by Anna Frances Simpson, high glaze pottery, impressed  
and incised marks and inscribed "FZ 81" in black  
*diameter 8 3/4in (22cm)*

**\$1,500 - 2,000**

**Provenance:**  
Private Collection, Northern California

6  
**GRUEBY FAIENCE COMPANY (FOUNDED 1894)**  
Bowl  
early 20th century  
modeled by Marie A. Seaman, glazed earthenware, impressed  
'GRUEBY POTTERY BOSTON U.S.A.' in a circle, incised MS  
*height 3 1/4in (8cm); diameter 6in (15cm)*

**\$1,800 - 2,500**

**Provenance:**  
Private Collection, Northern California

7  
**GRUEBY FAIENCE COMPANY (FOUNDED 1894)**  
Vase  
early 20th century  
glazed earthenware, impressed 'GRUEBY POTTERY BOSTON U.S.A.'  
in a circle obscured by glaze  
*height 11 3/4in (29cm); width 5 3/4in (14cm)*

**\$5,000 - 8,000**

**Provenance:**  
Private Collection, Northern California



8  
**ADELAIDE ALSOP ROBINEAU (1865-1929)**  
Vase  
1919  
crystalline glazed porcelain, molded mark, dated  
*height 6in (15cm)*

**\$2,500 - 3,500**

**Provenance:**  
Private Collection, Northern California

9  
**ADELAIDE ALSOP ROBINEAU (1865-1929)**  
Vase  
early 20th century  
crystalline glazed porcelain, incised mark  
*height 2 1/2in (6cm)*

**\$3,000 - 5,000**

**Provenance:**  
Private Collection, Northern California

10  
**MARBLEHEAD POTTERY (FOUNDED 1904)**  
Vase  
early 20th century  
decorated by Hannah Tutt, glazed earthenware, with artist's initials  
*height 4 1/2in (11cm)*

**\$1,200 - 1,800**

**Provenance:**  
Private Collection, Northern California



8

9



10

11

**NEWCOMB COLLEGE (1895-1940)**

Landscape Vase and Hyacinth Vase

circa 1930 and circa 1918

decorated by Anna Frances Simpson (1880 - 1930)

both with impressed and incised marks

height 5 1/4in and 5 3/4in (13cm and 14cm); width 2 1/2in and 3 1/4in (6cm and 8cm)

**\$2,000 - 3,000**

**Provenance:**

Private Collection, Northern California

12

**NEWCOMB COLLEGE (1895-1940)**

Two Vases

circa 1924

one vase decorated by Sadie Irvine (1887 - 1970), glazed earthenware, one with impressed and incised marks, the other bearing paper label obscuring factory marks

height 3 1/2in and 6in (8cm and 15cm); diameter 3 1/2in and 5in (8cm and 12cm)

**\$1,800 - 2,500**

**Provenance:**

Private Collection, Northern California



11



12

13

**ROOKWOOD POTTERY (FOUNDED 1880)**

Group of Nine Vases

early 20th century

matt glazed pottery, each with the firm's marks

heights 3 3/4in to 10 3/4in (9cm to 27cm)

**\$2,000 - 3,000**





14

**ROOKWOOD POTTERY (FOUNDED 1880)**

Group of Twelve Vases

early 20th Century

matt glaze pottery, each impressed with the firm's marks

heights 3 1/2in to 10 1/4in (8cm to 26cm)

**\$1,000 - 1,500**





15

**MURREL, BENNETT & CO. (FOUNDED 1891)**

Pendant

circa 1905

silver, amethyst, stamped with maker's mark and '950', on link chain  
pendant 2 x 1in (5 x 2.5cm); chain 7 1/2in (19cm)

**\$800 - 1,200**

**Provenance:**

Private Collection, Washington D.C.

16

**DIRK VAN ERP (1860-1933)**

Pair of Bookends

1920s

copper, glazed earthenware tile, impressed studio marks

height 6 1/2in (16.5cm); width 6 1/4in (15.8cm); depth 6 1/4in (15.8cm)

**\$1,000 - 1,500**

15



16

17

**LIBERTY & CO. (FOUNDED 1875)**

Table Clock

circa 1905

pewter, copper, stamped 'Tudric' and numbered on underside '0159'  
*height 6 1/2in (16.5cm); width 5 1/4in (13.4cm); depth 5 1/2in (14cm)*

**\$1,500 - 2,000**

18

**ENGLISH ARTS AND CRAFTS**

Table Clock

circa 1905

pewter, copper, enamel dial

*height 5 1/2in (14cm); width 3 1/4in (8.3cm); depth 2 1/8in (5.5cm)*

**\$1,500 - 2,000**

19

**ARCHIBALD KNOX (1864-1933)**

Five Piece Tea and Coffee Service with Tray

circa 1905

for Liberty & Co., pewter and rattan, comprising a coffee pot, teapot, water pot, sugar, creamer and tray, stamped 'Tudric' and variously numbered

*height of coffee pot 8in (22.2cm); length of tray 19in (49.5cm)*

**\$5,000 - 7,000**

**Provenance:**

The Maurice and Margo Cohen Collection of Decorative Arts,  
Christie's, New York, June 11 1999, lot 391

Collection of Barbara and Milford Nemer, Michigan



17



18



19

20 W

**HARVEY ELLIS (1852-1904)**

Set of Eight Dining Chairs

circa 1905

for Gustav Stickley, oak with original rush seats, signed with labels  
*height 40in (101cm); width 17in (43cm); depth 16in (41cm)*

**\$4,000 - 6,000**

**Provenance:**

Private Collection, Washington D.C.



21 W

**CHARLES SUMNER GREENE (1860 - 1957)  
AND HENRY MATHER GREENE (1870 - 1954)**

Dining Table

circa 1904

for the Camp house, Oregon pine

*height 30in; length 66 1/4in; depth 44in, with two 13 1/2in leaves*

**\$15,000 - 20,000**

The offered lot is one of the Greenes' earliest pieces of furniture. This table quite possibly may be the first piece of Greene & Greene furniture to have their signature "square edge" screw heads.

**Provenance:**

Edgar Camp House, Sierra Madre, California

Thence by descent

**Literature:**

Randell L. Makinson, 'Greene & Greene Architecture As Fine Art', Peregrine Smith, Inc., 1977, p. 90-91 (in-situ photograph, elevation and discussion of the Camp House)







22

22 W

**DONEGAL**

Carpet

circa 1900

wool

167in x 118in (426cm x 300cm)

**\$4,000 - 6,000**

**Provenance:**

Private Collection, Washington D.C.

23

**DIRK VAN ERP (1860-1933)**

Bean Pot Lamp

post 1915

hammered copper and mica, impressed  
studio mark

height 11in (27cm); diameter of shade 11in  
(27cm)

**\$3,000 - 5,000**

**Provenance:**

Private Collection, Northern California



23

24 W  
**DONEGAL**  
Carpet  
circa 1910  
machine woven wool  
161in x 118in (409cm x 302cm)

**\$3,000 - 5,000**

**Provenance:**  
Private Collection, Washington D.C.

25 W  
**GUSTAV STICKLEY (1858-1942)**  
Even Arm Settle  
circa 1900  
model 208, oak, leather  
height 29in (74cm); width 66in (168cm); depth  
32in (81cm)

**\$4,000 - 6,000**

**Provenance:**  
Private Collection, Washington D.C.



24



25

26 W

**AMERICAN**

Table Lamp

early 20th Century

leaded glass, patinated bronze

height 33in (83cm); diameter of shade 24in (60cm)

**\$3,000 - 5,000**



26

27

**TIFFANY STUDIOS (1899-1919)**

Pair of Candlesticks with Snuffers

circa 1910

Favrile glass, bronze, stamped 'Tiffany Studios New York 1212'

height 10 in (25cm)

**\$2,000 - 3,000**

**Provenance:**

Collection of Barbara and Milford Nemer, Michigan



27

28

**TIFFANY STUDIOS (1899-1919)**

Pair of Candlesticks

circa 1905

patinated bronze, stamped 'Tiffany Studios New York 1213'  
*height 16 3/4in (43cm)*

**\$2,000 - 3,000**

**Provenance:**

Private Collection, Washington D.C.



28

29

**TIFFANY STUDIOS (1899-1919)**

Bird Lamp

circa 1910

leaded glass, patinated bronze, shade tag stamped 'Tiffany Studios  
New York', base stamped 'Tiffany Studios New York'  
*height of base 24in (61cm); diameter of shade 16in (41cm)*

**\$6,000 - 8,000**



29







30  
**TIFFANY STUDIOS (1899-1919)**

Six Piece Venetian Desk Set  
circa 1910  
gilt bronze, comprising calendar frame, letter holder, pair of blotter ends, letter opener, rocker blotter, stamped 'Tiffany Studios New York' with various numbers  
*height of calendar 5 3/4in (14cm); width 6 1/2in (16cm); depth 3in (7cm)*

**\$1,000 - 1,500**

31  
**TIFFANY STUDIOS (1899-1919)**

Picture Frame  
circa 1910  
patinated bronze, Favrile glass, stamped 'Tiffany Studios New York 947'  
*height 9in (22.8cm); width 8in (20.32cm); depth 4in (10.16cm)*

**\$1,200 - 1,800**

32  
**TIFFANY STUDIOS (1899-1919)**

Counter Balance Desk Lamp  
circa 1910  
damascene glass, patinated bronze, shade engraved 'L.C.T. Favrile', base stamped 'TIFFANY STUDIOS NEW YORK 416'  
*height of base 13in (33cm); diameter of shade 6 1/2in (17cm)*

**\$3,000 - 5,000**

33  
**TIFFANY STUDIOS (1899-1919)**

Pair of Cat Bookends  
circa 1910  
patinated bronze, stamped 'Tiffany Studios New York'  
*height 6 1/2in (16.5cm); width 7in (17.7cm); depth 7 1/2in (19cm)*

**\$5,000 - 7,000**



33

34

**TIFFANY STUDIOS (1899-1919)**

Student Lamp

1903

decorated Favrile glass, patinated bronze, shade inscribed 'S 4309';  
base stamped 'Tiffany Studios New York 101'  
*height 19in (48.3cm)*

**\$3,000 - 5,000**

35

**TIFFANY STUDIOS (1899-1930)**

Three-Light Lily Lamp

circa 1910

Favrile glass, patinated bronze, one shade inscribed 'L.C.T.'; base  
stamped 'Tiffany Studios New York 319'  
*height 12in (33cm)*

**\$2,000 - 3,000**

36

**TIFFANY STUDIOS (1899-1919)**

Favrile Glass and Bronze Lamp

circa 1910

Favrile glass, patinated bronze, shade inscribed 'L.C.T.-FAVRILE'; oil-  
font impressed with Tiffany Glass and Decorating Co. monogram  
*height 12in (30.5cm); diameter 7in (17.8cm)*

**\$4,000 - 6,000**



34



35



36

37

**TIFFANY STUDIOS (1899-1930)**

Pair of Mantle Lamps

circa 1910

patinated bronze, Favrite glass, the shades engraved 'L.C.T.' the bases

stamped 'TIFFANY STUDIOS NEW YORK 322'

height 14in (35cm)

**\$4,000 - 6,000**

**Provenance:**

Geoffrey Diner Gallery

Private Collection, Washington D.C.





38 W

**TIFFANY STUDIOS (1899-1919)**

Counter Balance Floor Lamp

circa 1910

gilt bronze, Favrite glass, the shade engraved 'L.T.C. Favrite'

height of base 55 1/4in (140cm); diameter of shade 10 1/4in (26cm)

**\$2,500 - 3,500**

39 W

**TIFFANY STUDIOS (1899-1919)**

Acorn Lamp

circa 1910

leaded glass, patinated bronze, shade stamped 'Tiffany Studios New

York; base stamped 'Tiffany Studios New York 9944'

height 22in (56cm); diameter of shade 16in (41cm)

**\$6,000 - 8,000**



38

39

40

**TIFFANY STUDIOS (1899-1919)**

Ten-Light Lily Lamp

circa 1910

gilt bronze, Favrite glass, base stamped 'Tiffany Studios New York

381', five shades engraved 'L.C.T.'; four shades engraved 'L.C.T.

Favrile'; one shade engraved 'L.C. Tiffany Favrite'

height 20 1/2in (52cm)

**\$15,000 - 20,000**





41 W

**AGATHON LÉONARD (1841-1923)**

Danseuse à l'écharpe

circa 1900

gilt bronze, inscribed 'A Leonard Sculp', stamped with Susse Freres

Paris foundry seal

height 24in (60.9cm); width 18 1/2in (46.9cm); depth 7 1/4in (18.4cm)

**\$10,000 - 15,000**



41

42 W

**AGATHON LÉONARD (1841-1923)**

Tambourins

circa 1900

gilt bronze, inscribed 'A Leonard Sculp', stamped with Susse Freres

Paris foundry seal and 'M'

height 18in (45.7cm); width 8 1/2in (21.5cm); depth 7 1/2in (19cm)

**\$10,000 - 15,000**



42



43

43  
**MAX BLONDAT (1879-1926)**  
 Fontaine Jeunesse ou Fontaine aux Grenouilles  
 1907  
 patinated bronze, inscribed 'MAX BLONDAT'  
 height 14in (36cm); width 12in (31cm); depth 15in (38cm)

**\$6,000 - 8,000**

44 W  
**PAUL-FRANCOIS BERTHOUD (BORN 1870)**  
 'Femme-Libellule'  
 circa 1900  
 parcel gilt and patinated bronze, inscribed 'P.F. Berthoud', stamped  
 'Paris Louchet Ciseleur'  
 height 24 3/4in (62cm); width 13 1/2in (34cm) depth 14 1/4in (36cm)

**\$12,000 - 18,000**



44

45  
**ÉMILE GALLÉ (1846-1904)**  
Chrysanthemum Vase  
circa 1900  
cameo glass, signed 'Gallé'  
height 5 1/2in (14cm)

**\$2,000 - 3,000**

**Provenance:**  
Private Collection, Northern California

46  
**ÉMILE GALLÉ (1846-1904)**  
Crocus Vase  
circa 1900  
cameo glass, signed 'Gallé'  
height 8 1/2in (22cm)

**\$3,000 - 4,000**

**Provenance:**  
Private Collection, Northern California



45



46

47  
**DAUM FRÈRES (ESTABLISHED 1878)**  
Prunus Vase  
circa 1900  
overlaid and wheel-carved glass, acid etched  
mark 'Daum Nancy' with the Cross of  
Lorraine  
*height 9in (23cm); diameter 4 3/4in (12cm)*

**\$5,000 - 7,000**

48  
**DAUM NANCY (FOUNDED 1825)**  
Covered Box  
circa 1900  
overlaid, etched, wheel-carved and marteled  
glass  
signed 'Daum Nancy' with the Cross of  
Lorraine  
*height 2 1/2in (6.3cm); diameter 6in (15.2cm)*

**\$1,500 - 2,500**

**Provenance:**  
Private Collection, Los Angeles, California

49  
**ÉMILE GALLÉ (1846-1904)**  
Rare Egyptian Vase  
circa 1925  
clear and opalescent glass, overlaid, acid-  
etched and fire polished, intaglio mark 'Gallé'  
*height 10 1/8in (26cm); diameter 10 1/2in (27cm)*

**\$15,000 - 20,000**



47



48



49



50

**AMPHORA (FOUNDED 1892)**

Group of Three Vases

circa 1900

porcelain, comprising a two handled vase with moth and flower decoration; an "Allegory of Germany" bottle vase, possibly by Nikolaus Kannhauser; and a beaker vase with pierced rim, designed by Paul Daxsel, each marked 'Turn Teplitz'; two handled vase with further impressed Amphora marks  
*height of tallest 12 1/2in (32cm); height of shortest 5 1/2in (14cm)*

**\$1,500 - 2,000**

**Provenance:**

John Cobabe, Redondo Beach, California

Private Collection, Northern California



51

**DAUM NANCY (FOUNDED 1825)**

Vase

circa 1900

martele glass, engraved 'Daum Nancy' with the Cross of Lorraine  
height 11 3/4in (30cm)

**\$5,000 - 7,000**



51

52

**DAUM NANCY (FOUNDED 1825)**

Vase

circa 1900

martele glass  
signed 'Daum Nancy' with the Cross of Lorraine  
height 11 1/2in (29.2cm)

**\$6,000 - 8,000**

**Provenance:**

Private Collection, Los Angeles, California



52

53 W

**DAUM NANCY (FOUNDED 1825)**

Thistle Vase

circa 1900

acid etched, enameled and gilt decorated glass

signed 'Daum Nancy' with the Cross of Lorraine

height 29in (73.6cm); width

**\$7,000 - 9,000**

**Provenance:**

Private Collection, Los Angeles, California



54 W

**ÉMILE GALLÉ (1846-1904)**

Dragonfly Vase

circa 1900

cameo glass, signed 'Gallé'

height 28in (71cm)

**\$6,000 - 9,000**



55

**ÉMILE GALLÉ (1846-1904)**

Intercalaire Marine Vase

circa 1900

dense internally decorated and wheel carved glass with surface craquelure, carved 'Gallé'  
*height 8 3/4in (22cm); width 4 3/4in (12cm); depth 4in (10cm)*

**\$3,000 - 5,000**

**Provenance:**

Brugnot, Paris

Acquired from the above, 1979

Areta Kaufman



55

56<sup>W</sup>

**DAUM NANCY (FOUNDED 1825)**

Vase

circa 1900

acid etched and enameled glass  
signed 'Daum Nancy' with the Cross of Lorraine  
*height 21in (53.3cm)*

**\$5,000 - 7,000**

**Provenance:**

Private Collection, Los Angeles, California



56



57

**RENÉ LALIQUE (1860-1945)**

Ceylan Vase

Marcilhac 905, model introduced 1924

molded opalescent glass, engraved 'R LALIQUE FRANCE'  
and etched '905'

height 9 1/2in (24cm)

**\$2,500 - 3,500**

**Provenance:**

Le Style Lalique, London

Private Collection, Northern California



57

58

**RENÉ LALIQUE (1860-1945)**

Perch Paperweight

Marcilhac 1158, design introduced 1929

opalescent glass, signed 'Lalique France'  
height 4in (10cm); length 6 1/2in (17cm)

**\$1,000 - 1,500**



58

59 W

**MARC LALIQUE (1900-1977)**

Cactus Center Table  
design introduced 1951  
molded frosted glass, plate glass, etched 'Lalique France'  
height 28 5/16in (71.8cm); diameter 62 1/8in (157.7cm)

**\$25,000 - 35,000**

**Provenance:**

L.D. "Brink" Brinkman Collection, Kerrville, Texas

60 W

**MARC LALIQUE (1900-1977)**

Cactus Center Table  
design introduced 1951  
molded frosted glass, plate glass, etched 'Lalique France'  
height 28 9/16 (72.3cm); diameter 60in (152.4cm)

**\$25,000 - 35,000**

**Provenance:**

L.D. "Brink" Brinkman Collection, Kerrville, Texas



60



59

61

**RENÉ LALIQUE (1860-1945)**

Avallon Vase

Marcihac 986, model introduced 1927  
molded glass, engraved 'R. LALIQUE FRANCE'  
height 5 3/4in (15cm); diameter 5 1/2in (14cm)

**\$2,000 - 3,000**



61

62

**RENÉ LALIQUE (1860-1945)**

Sophora Vase

Marchillac 977, designed in 1926  
frosted and polished glass, molded 'R. Lalique' and etched 'R. Lalique  
France'  
height 10 1/2in (27cm)

**\$5,000 - 7,000**

**Provenance:**

Private Collection, Los Angeles, California



62

63

**RENÉ LALIQUE (1860-1945)**

Thais Statuette

Marcihac 834, model introduced 1925

molded opalescent glass, metal

signed 'R. Lalique, France 9/1884'

height 8 1/2in (21.5cm); width 7 1/2in (19cm); 2 1/4in (5.7cm)

**\$6,000 - 8,000**

**Provenance:**

Private Collection, Northern California





64

**RENÉ LALIQUE (1860-1945)**

Gobelet Six Figurines Vase

Marcilhac 903, model introduced 1912

opalescent glass

height 7 1/2in (19cm); diameter 5 1/2in (13.9cm)

\$2,000 - 3,000



65

**RENÉ LALIQUE (1860-1945)**

Frise De Perruches Vase

1913 - 1916

cire perdue glass with blue and grey two-tone patina, engraved 'R LALIQUE'

height 7 1/2in (19.05cm); diameter 5 1/2in (13.97cm)

**\$40,000 - 60,000**

The offered lot is the earliest known Perruches vase to have been created by René Lalique.

**Literature:**

Felix Marcilhac, 'R. Lalique Catalogue Raisonné', Les Editions de l'Amateur', 1994, p. 997 (variant vase illustrated)



66

**PAUL BELVOIR (BORN 1963)**

Bowl

2011

sterling silver, rock crystal and amethyst, hallmarked and stamped 'PGB' to the underside of the base  
*height 5 1/8in (13cm); diameter 13 3/8in (34cm)*

**\$8,000 - 10,000**

**Provenance:**

Adventures in Style: Hamish Bowles & Gordon Watson, Bonhams, New York, 13 November, 2012  
Estate of Gerard L. Cafesjian

67

**STEBEN (FOUNDED 1903)**

Modernist Bud Vase

1970s

cut glass, with original fitted Steuben box, etched 'Steuben' on underside  
*height of vase 7in (17.8cm); width 4.5in (11.4cm); depth 4.5in (11.4cm)*

**\$1,500 - 2,000**

**Provenance:**

Private Collection, Northern California



66

68

**RENÉ LALIQUE (1860-1945)**

Pair of Tokyo Candlesticks

Marcilhac 2119, model introduced 1935

molded glass, each engraved 'R. LALIQUE FRANCE'

*height 8 1/2in (21.6cm); width 4 3/4in (12.1cm); depth 2 1/8in (5.5cm)*

**\$1,500 - 2,000**

**Provenance:**

Le Style Lalique, London  
Private Collection, Northern California

69

**ÉMILE GALLÉ (1846-1904)**

Bullseye Vase

circa 1900

glass, engraved 'E. Gallé Nancy'

*height 6 1/4in (15.9cm)*

**\$1,000 - 1,500**

**Provenance:**

The Emmerton House, Salem, Massachusetts  
Bullseye Gallery, Boston, Massachusetts



67



69

68

70

**SIMON GATE (1883-1945)**

Centerpiece and Underplate  
designed 1920, engraved 1925  
for Orrefors, engraved, frosted and polished glass; underplate  
engraved 'Orrefors.Gate 147.25 W.E.'  
*height 4 1/2in (11.5cm); width 15in (38cm); depth 9in (23cm)*

\$3,000 - 5,000

**Provenance:**

Private Collection, New York

**Literature:**

Helmut Ricke and Lars Thor, 'Swedish Glass Factories Production  
Catalogues 1915-1960', Prestel-Verlag, p. 27 (original design drawing  
illustrated)







71

71 W

**CLEOPATRA VLADIMIROVNA  
BEKLEMICHEVA (1898-1976)**

Figure of a Nude

Circa 1925

patinated bronze, stamped faintly C

BECEMICHEFF

height 40in (102cm); width 17in (43cm); depth  
8 1/2in (22cm)

**\$2,000 - 4,000**

72 W

**FRENCH  
COMPANION SECRETAIRE AND VITRINE**

circa 1940

carved mahogany, leather, glass

height of each 54in (137cm); width 34in  
(86cm); depth 16 1/4in (41cm)

**\$3,000 - 5,000**

**Provenance:**

Robert Willson, Los Angeles, California



72

73 W

**STAN P. PORAY (1888-1948)**

Portrait of Philip G. Benz Jr.

1938

oil on canvas, signed lower right 'Stan Pocięcha Poray' and dated '1938'  
height 48 1/2in (123.1cm); width 45 1/4in (114.9cm); depth 2 1/4in (5.7cm)

**\$2,000 - 3,000**

**Provenance:**

Robert Willson, Los Angeles, California

**Exhibited:**

California Commission for the Golden Gate International Exposition



73

74 W

**CHARLES DUDOUYT (1903-1969)**

Cabinet

circa 1940

carved, cerused oak, brass

height 64in (163cm); width 88in (223.5cm);  
depth 18in (45.5cm)

**\$3,000 - 5,000**

**Provenance:**

Robert Willson, Los Angeles, California



74



75

75<sup>Y</sup>

**JEAN E. PUIFORCAT (1887-1945)**

Five Piece Tea and Coffee Set

designed circa 1928

silverplate, Indian rosewood

comprising a coffee pot, tea pot, creamer, sugar and serving tray, stamped 'Puiforcat France' and with maker's hallmark

height of coffee pot 8in (20cm); length of tray 28in (71cm)

**\$2,000 - 3,000**

**Provenance:**

Collection of Barbara and Milford Nemer, Michigan

76<sup>W</sup>

**CHARLES DUDOUYT (1903-1969)**

Cabinet

circa 1940

cerused oak, mirrored

height 38in (96.5cm); width 60 1/4in (153cm); depth 20 1/2in (52cm)

**\$2,500 - 3,500**

**Provenance:**

Robert Willson, Los Angeles, California



76



77

77

**JEAN E. PUIFORCAT (1887-1945)**

Letter Opener with Sheath

1942-1945

mahogany, studs, stamped with maker's hallmark  
length 8in (20.32cm); width 1 3/8in (3.47cm)

**\$3,000 - 5,000**

The offered lot was created during the time Puiforcat was working in Mexico

78 W<sup>Y</sup>

**JEAN PASCAUD (1903-1996)**

Pair of Side Tables

circa 1925

rosewood, glass

height 24in (61cm); width 20in (51cm); depth 12in (30cm)

**\$2,500 - 3,500**

**Provenance:**

Calderwood Gallery, Philadelphia, Pennsylvania, 1982

Collection of Barbara and Milford Nemer, Michigan



78

79

**POUL HENNINGSEN (1894-1967)**

Early Table Lamp, Type 3 1/2 Shades

1927-28

for Louis Poulsen, brass, enameled brass, opal glass, stamped PAT.

APPL

height 17 1/2in (44.5cm); diameter 13 1/2in (34.5cm)

\$4,500 - 5,500

**Provenance:**

Private Collection, Copenhagen

**Literature:**

Louis and Tina Jørstian, Poul Erik Munk Nielsen, 'Light Years Ahead: The Story of the PH Lamp', Louis Poulsen, 1994, p. 147-51





**GEORG JENSEN (1866-1935)**

Pyramid Pattern Silver Service

post 1945

sterling silver, comprising eight dinner forks, eight salad forks, two cocktail forks, eight dinner knives, one butter knife, eight soup spoons, eight tea spoons, eight demitasse spoons, one table spoon, one sugar spoon, carving fork and knife, large serving spoon, ladle, serving knife, serving fork, salt and pepper shakers, bottle opener stamped 'Georg Jensen STERLING DENMARK'

**\$4,000 - 6,000**



81

81 W

**DAUM NANCY (FOUNDED 1825)**

Elephant Table Lamp

early 20th Century

cameo glass, wrought iron, shade etched 'Daum Nancy' with Cross of Lorraine

height 24 1/2in (62.2cm); diameter of shade 14 1/4in (36.1cm)

**\$1,500 - 2,500**

82 W

**MICHEL ZADOUNAISKY (1903-1983)**

Pair of Cocktail Tables

circa 1925

patinated iron, marble, one table stamped 'ZADOUNAISKY'

height 14 3/4in (37.5cm); width 33 1/2in (85cm); depth 17in (43cm)

**\$3,000 - 5,000**



82

83

**EDGAR BRANDT (1880-1960)**

Table Lamp  
circa 1925  
wrought iron, alabaster  
*height 15in (38cm)*

**\$2,500 - 3,500**

**Provenance:**

Calderwood Gallery, Philadelphia, Pennsylvania  
Collection of Barbara and Milford Nemer, Michigan



83

84

**FRENCH**

Two Light Lamp  
early 20th century  
mottled glass, patinated bronze, shades engraved 'Daum Nancy' with  
the Cross of Lorraine  
*height 18 1/4in (46.4cm); width 14 1/4in (36.1cm); depth 9in (22.9cm)*

**\$3,000 - 4,000**



84

85

**MEINRAD BURCH-KORRODI (1897-1978)**

Three Piece Tea Set

circa 1950

hammered sterling silver, walnut, comprising a tea pot with cover, sugar bowl with cover and a creamer, each stamped with the maker's mark and 925

*height of tea pot 9 1/2in (24cm); length of sugar bowl 4 1/2in (11cm)*

**\$2,500 - 3,500**



85

86

**RENÉ LALIQUE (1860-1945)**

Monnaie du Pape Coffret

Marchillac 350, model introduced 1914

molded glass, walnut, wheel carved 'R. Lalique'

*height 4 3/4in (12.1cm); length 12 1/2in (31.7cm); depth 7 3/4in (19.7cm)*

**\$6,000 - 8,000**

**Provenance:**

Private Collection, Los Angeles, California



86

87 W

**FRENCH MODERNIST**

Secrétaire

circa 1930

macassar ebony

height 56in (142.2cm); width 72 3/4in (184.7cm); depth 19in (48.2cm)

**\$2,500 - 3,500**



87

88 W

**BORIS LOVET-LORSKI (1894-1973)**

Entwined Cranes

1960s

gilt and patinated bronze

height 65in (165cm); diameter of base 13 1/2in (34cm)

**\$2,000 - 3,000**



88



89 W

**ROBERTO AND MITO BLOCK (ACTIVE MID-20TH CENTURY)**

Custom Cabinet

1940s

mahogany, brass

height 34 1/4in (87cm); width 108in (274.3cm); depth 23 1/2in (59cm)

**\$4,000 - 6,000**

**Provenance:**

Robert Willson, Los Angeles, California



90 W

**ANDRÉ RENOU (1912-1980) AND JEAN-PIERRE GENISSET (1911-1998)**

La Crémaillère Dining Table

1951

wrought-iron with gilt finish, mahogany

height 28 1/4in (72cm); width 108 1/2in (276cm); depth 34 3/4in (88.5cm)

**\$10,000 - 15,000**

**Provenance:**

Hotel and Restaurant La Croix du Sud, Dakar, Senegal

'20th Century Decorative Art & Design', Christie's, New York, 26

March, 2008;

Acquired directly from the above



90



91



92

91 W

**FRENCH**

Assorted Group of 75 Wallpaper and Textile Designs  
1875-1975  
gouache on paper  
*smallest 15 x 17 3/4in (38cm x 45cm); largest 23 1/8 x 31 3/8in (59 x 80cm)*

**\$4,000 - 6,000**

The present lot is offered together with a copy of the F. Hardivillier-Cacheux Archives catalogue, from where the lot was acquired.

**Provenance:**

ESSEF Balagny sur Therain, France  
Beauvais Auction House, France, March & September 2007

92 W

**LOUIS SÛE (1875 - 1968) AND ANDRE MARE (1885 - 1932)**

Canape  
1923  
carved mahogany, parcel gilt, upholstered  
*height 34 1/2in (87.5cm); width 84in (213.5cm); 32in (81cm)*

**\$6,000 - 8,000**

**Provenance:**

Robert Willson, Los Angeles, California

**Literature:**

Florence Camard, Sûe et Mare: Et la Compagnie des art Francais;  
Editions d l'Amateur, 1996 p.137, model illustrated

93 W

**EMILE JACQUES RUHLMANN (1869-1933)**

Bedstead  
circa 1925  
amboyna, gilt bronze, branded 'Ruhlmann' to the footboard and headboard, the rail painted  
*height 40in (102cm); width 66 1/2in (169cm); length 78 1/2in (199cm)*

**\$15,000 - 20,000**



93







94 W

**AFTER JACQUES CINQUIN (BORN 1942)**

New York Tapestry  
for Atelier Gisele Brivet/Aubusson, wool, signed in the weaving  
'Cinquin' and 'GB', with fabric label on the reverse, titled 'New York',  
signed, and marked 'E/A'  
84 x 52in (213 x 132cm)

**\$3,000 - 5,000**

**To be sold without reserve**

**Provenance:**

Ziuta Gerstenzang Akston (1901-1994) and Joseph James Akston  
(1895-1983), Palm Beach, Florida  
Thence by Descent

95 W

**JOSEPH CSAKY (1888-1971)**

Figure Dite Aussi Cônes et Sphères  
circa 1974  
for Atelier Csaky, after the original model designed 1919, patinated  
bronze, engraved 'CSAKY', numbered '1/8' and with foundry mark for  
Blanchet Fondateur  
height 27 1/2in (70cm); width 6 1/2in (16.5cm)

**\$40,000 - 50,000**

Joseph Csaky was one of the most important avant-garde sculptors of the 20th Century. His powerful cubist bronze works relate to the linear elements in the paintings of his contemporaries, Georges Braque and Pablo Picasso. Pieces by Csaky are represented in the permanent collections of the Solomon R. Guggenheim Museum in New York as well as the Musée National d'Art Moderne in Paris.

**Literature:**

Félix Marilhac, 'Joseph Csaky', Catalogue Raisonné des Sculptures,  
Les Editions de l'Amateur, 2007, p. 318 (model illustrated)





96

96 W

**DONALD DESKEY (1894-1989)**

Companion Pair of Mirrors

1930s

glass, chromed metal

*diameters 36in (92cm) and 30in (76cm)*

**\$5,000 - 7,000**

97 W

**ARTURO PANI (1915-1981)**

Center Table

1950s

enameled metal, glass

*height 27 3/4in (70.4cm); diameter 45 3/4in (116.2cm)*

**\$1,800 - 2,500**

**Provenance:**

Robert Willson, Los Angeles, California



97



98

98 W

**ALEXANDER LIBERMAN (1912-1999)**

Untitled VII

1995

watercolor on paper, signed and dated lower right 'Liberman 95'  
40 x 60in (102 x 153cm)

**\$2,000 - 3,000**

**Provenance:**

Andre Emmerich Gallery, New York  
Collection of Barbara and Milford Nemer, Michigan

99 W

**PAUL T. FRANKL (1886-1958)**

Speed Chair and Ottoman

1946 - 1949

upholstered

height of chair 29 1/4in (29.2cm); width 36 3/4in (93.3cm); depth  
42in (106.6cm); height of ottoman 14 1/2in (36.8cm); width 26 1/2in  
(67.3cm); depth 18 1/2in (46.9cm)

**\$10,000 - 15,000**

**Provenance:**

Charlton Heston, Beverly Hills, California

**Literature:**

Christopher Long, 'Paul T. Frankl and Modern American Design', Yale  
University Press, 2007, p.152 (chair model variant illustrated)



99



## Rare Radios from the Collection of Johnny Hubbard

Johnny Hubbard always had a fascination with anything shiny, detailed, handcrafted. He began collecting radios in the 1970s buying a 1931 Philco 70 "Cathedral" style radio. Refurbishing that one cathedral radio led to buying, selling, and trading other radios. Johnny's love for the beauty and craftsmanship in these radios spread to all kinds of other simple machines made during the early 1900s. Soon his collection included just about anything produced during that eclectic, modern age of luxury known as the Art Deco period, especially anything made of Catalin or Bakelite.

Johnny met many other expert collectors as he travelled in search of the next fantastic find. He had friends from many parts of the United States and Europe. He travelled to radio meets and deco shows and purchased from dealers and collectors to acquire the best radios and deco items he could find. He mentored the younger of his friends who were beginning their journey into the world of the collector. His guidance reinforced their desire to collect the best treasures they could find. He was well known, respected, and loved by the radio collector community and the many friends he made along the way. It was his desire to share his legacy with other fellow collectors and know that his prize pieces will be cherished by kindred spirits.

100

**FADA RADIO AND ELECTRIC CO. INC. (FOUNDED 1920)**

Two 53X Radios

circa 1938

onyx catalin with matching knobs and inset louvered grille and yellow catalin case and knobs with inset blue louvered grille, each with FADA Radio decal

height 5 1/2in (14cm); width 8 3/4 (22.3cm); depth 5in (12.7cm)

**\$2,000 - 3,000**

**Literature:**

John Sideli, 'Classic Plastic Radios of the 1930s and 1940s', E.P. Dutton, 1990, p. 63-64 (model variant illustrated)

101

**FADA RADIO AND ELECTRIC CO. INC. (FOUNDED 1920)**

53X Radio

Circa 1938

yellow catalin case and knobs with red louvered grille, with FADA radio decal

height 5 1/2in (14cm); width 8 3/4in (22.3cm); depth 5in (12.7cm)

**\$2,500 - 3,500**

**Literature:**

John Sideli, 'Classic Plastic Radios of the 1930s and 1940s', E.P. Dutton, 1990, p. 63 (model illustrated)



100



100

101



102

**EMERSON RADIO & PHONOGRAPH CORPORATION (FOUNDED 1922)**

Cathedral Radio

1937

espresso brown catalin with matching knobs, cloth grille  
*height 9 1/4in (23.4cm); width 7 1/4in (18.4cm); depth 6in (15.24cm)*

**\$2,000 - 3,000**

**Literature:**

John Sideli, 'Classic Plastic Radios of the 1930s and 1940s', E.P. Dutton, 1990, p. 46-47 (model illustrated)

103

**EMERSON RADIO & PHONOGRAPH CORPORATION (FOUNDED 1922)**

Cathedral Radio

1937

green catalin with matching knobs, cloth grille, with partial Emerson decal  
*height 10in (25.4cm); width 7 1/4in (18.4cm); depth 6in (15.24cm)*

**\$3,000 - 5,000**

**Literature:**

John Sideli, 'Classic Plastic Radios of the 1930s and 1940s', E.P. Dutton, 1990, p. 46-47 (model illustrated)



102



103

104

**EMERSON RADIO & PHONOGRAPH CORPORATION (FOUNDED 1922)**

Two BT 245 Cathedral Radios

1938

green catalin case, white louvered grille and deep red catalin case, white louvered grille, both marked with Emerson treble decal  
*height 10in (25.4cm); width 7 1/4in (18/4cm); depth 5in (12.5cm)*

**\$1,500 - 2,000**

The shape of the offered lot is referred to amongst collectors as a "tombstone".

**Literature:**

John Sideli, 'Classic Plastic Radios of the 1930s and 1940s', E.P. Dutton, 1990, p. 48-49 (model illustrated)



105

**INTERNATIONAL RADIO CORPORATION (1931-1940)**

Kadette K 25 Clockette

1937

green catalin with matching knobs, brass, metal mesh, with KADETTE  
decal on face

height 8 1/4in (20.9cm); width 7 3/4in (19.8cm); depth 5 1/2in (14cm)

\$4,000 - 6,000

**Literature:**

John Sideli, 'Classic Plastic Radios of the 1930s and 1940s', E.P.  
Dutton, 1990, p. 103 (model illustrated)



106

**INTERNATIONAL RADIO CORPORATION (1931-1940)**

Kadette K-25 Clockette

1937

red catalin with matching knobs, brass, metal mesh, with KADETTE  
decal on face

height 8 1/4in (20.9cm); width 8in (20.32cm); depth 5 3/4in (14.6cm)

**\$6,000 - 8,000**

**Literature:**

John Sideli, 'Classic Plastic Radios of the 1930s and 1940s', E.P.  
Dutton, 1990, p. 103 (model illustrated)



107

**FADA RADIO AND ELECTRIC CO. INC. (FOUNDED 1920)**

L 56 Radio

1939

maroon catalin case and handle with yellow knobs and wraparound grille, with FADA Radio decal

*height 6 1/2in (16.51cm); width 9in (22.86cm); depth 6 1/2in (16.51cm)*

**\$1,500 - 2,500**

**Literature:**

John Sideli, 'Classic Plastic Radios of the 1930s and 1940s', E.P. Dutton, 1990, p. 67 (model illustrated)



107

108

**FADA RADIO AND ELECTRIC CO. INC. (FOUNDED 1920)**

L 56 Radio

1939

yellow catalin with matching knobs and handle and green wraparound grille, with FADA Radio decal

*height 6 3/4in (17.14cm); width 9in (22.86cm); depth 6 1/2in (16.51cm)*

**\$3,000 - 5,000**

**Literature:**

John Sideli, 'Classic Plastic Radios of the 1930s and 1940s', E.P. Dutton, 1990, p. 67 (model illustrated)



108



109

**GENERAL TELEVISION AND RADIO CORP. (FOUNDED 1932)**

Group of Three Radios

1940 and 1947

comprising two 591 catalin radios in yellow and deep red with off white grille, handle, dial bezel and knobs; together with a green Tenite 5A5 radio in the same style, dials marked 'General Television'

*height 7 1/4in (18.41cm); width 8 3/4in (22.22cm); depth 5 1/2in (13.97cm)*

**\$3,800 - 4,800**

**Literature:**

John Sideli, 'Classic Plastic Radios of the 1930s and 1940s', E.P. Dutton, 1990, p. 101 (model variant illustrated)



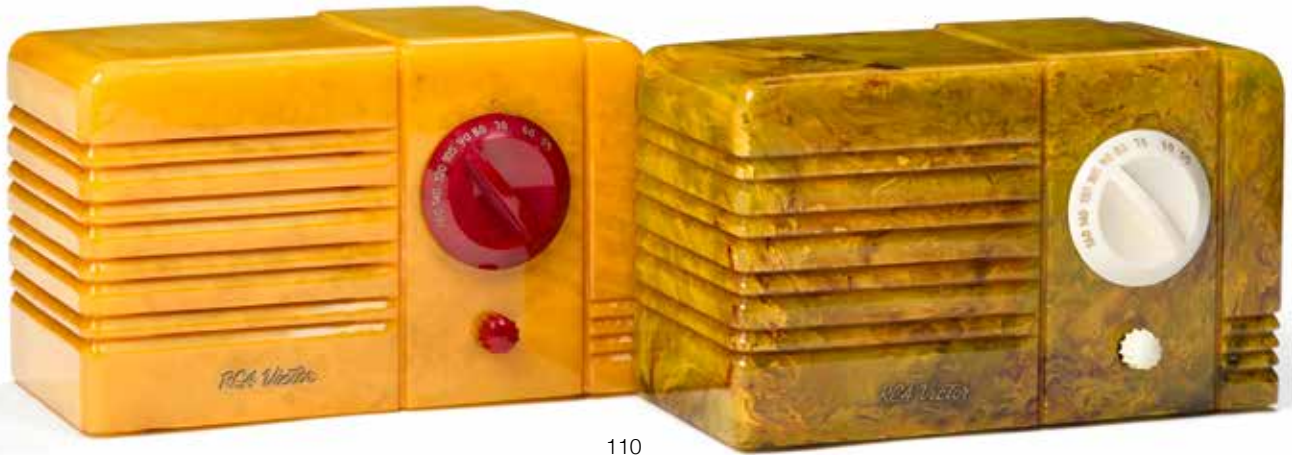

110

110

**RCA VICTOR (FOUNDED 1919)**

Two Little Nipper II Radios

1939

model 9-TX, green catalin and yellow catalin cases, both with RCA Victor decals on face

height 5 1/4in (13.33cm); width 8 3/4in (22.22cm); depth 4 1/2in (11.43cm)

**\$1,500 - 2,000**

**Literature:**

John Sideli, 'Classic Plastic Radios of the 1930s and 1940s', E.P. Dutton, 1990, p. 113 (model illustrated)

111

**FADA RADIO AND ELECTRIC CO. INC. (FOUNDED 1920)**

Two FADA 1000 Bullet Radios

1945

blue catalin case with yellow handle, dial bezel and knobs and all yellow radio, both dials marked 'FADA'

height 6 1/2in (16.5cm); width 10in (25.5cm); depth 5 3/4 (14.5cm)

**\$2,500 - 3,800**

**Literature:**

John Sideli, 'Classic Plastic Radios of the 1930s and 1940s', E.P. Dutton, 1990, p. 71-74 (model illustrated)



111

112

**EMERSON RADIO & PHONOGRAPH CORPORATION (FOUNDED 1922)**

Little Miracle Radio

1938

model AX235, cherry red catalin case with white louvered grille and off white knobs with Emerson decal

height 5 3/4in (14.6cm); width 8 1/2in (21.59cm); depth 4 1/2in (11.43cm)

**\$2,000 - 3,000**

**Literature:**

John Sideli, 'Classic Plastic Radios of the 1930s and 1940s', E.P. Dutton, 1990, p. 51 (model illustrated)





113

113  
**FADA RADIO AND ELECTRIC CO. INC. (FOUNDED 1920)**  
 Two 711 Radios  
 1946  
 onyx and blue catalin with metal mesh grille, each marked FADA on dial  
*height 6 3/4in (17.14cm); width 9 1/2in (24.13cm); depth 6in (15.24cm)*

**\$1,500 - 2,000**

**Literature:**

John Sideli, 'Classic Plastic Radios of the 1930s and 1940s', E.P. Dutton, 1990, p. 87 (model variant illustrated)

114  
**MOTOROLA (FOUNDED 1928)**  
 Two Circle Grille 50XC Radios  
 1940  
 marbled catalin case with matching translucent tortoise speaker bezel, handle and knobs and all yellow catalin, both marked 'Motorola' on dial  
*height 6 1/5in (16.5cm); width 9 3/4in (24.8cm); depth 6 1/4 (16cm)*

**\$2,000 - 3,000**

**Literature:**

John Sideli, 'Classic Plastic Radios of the 1930s and 1940s', E.P. Dutton, 1990, p. 108-109 (model illustrated)



114





115

**RCA VICTOR (FOUNDED 1919)**

Two RC350 Radios

1938

brown and yellow catalin cases, brass dial bezels, cloth grilles, each with RCA Victor partial decal

*height 4 3/4in (12.06cm); width 7in (17.78cm); depth 4 1/4in (10.79cm)*

**\$2,000 - 3,000**

**Literature:**

John Sideli, 'Classic Plastic Radios of the 1930s and 1940s', E.P. Dutton, 1990, p. 112 (model illustrated)





116

**GAROD (FOUNDED 1924)**

1B55L Radio

1940

maroon catalin case with yellow knobs, grille and drop handle, with GAROD decal

height 7in (17.78cm); width 11 1/2in (29.21cm); depth 6 1/4in (15.87cm)

**\$2,000 - 3,000**

**Literature:**

John Sideli, 'Classic Plastic Radios of the 1930s and 1940s', E.P. Dutton, 1990, p. 90 (model illustrated)

117

**CROSLEY RADIO CORP. (FOUNDED 1921)**

G1465 Radio

1938

maroon catalin case with yellow knobs and split wraparound grille, marked 'CROSLEY' on dial

height 5 3/4in (14.6cm); width 9 1/2in (24.13cm); depth 4in (10.16cm)

**\$2,000 - 3,000**

**Literature:**

John Sideli, 'Classic Plastic Radios of the 1930s and 1940s', E.P. Dutton, 1990, p. 40 (model illustrated)



116



117

118

**EMERSON RADIO & PHONOGRAPH CORPORATION  
(FOUNDED 1922)**

Five Plus One Radio

1941

model EP375, blue catalin case and handle with tan bars and knobs  
*height 6 1/2in (17cm); width 9 1/2in (24cm); 5 1/2in (14cm)*

**\$4,000 - 6,000**

**Literature:**

John Sideli, 'Classic Plastic Radios of the 1930s and 1940s', E.P. Dutton, 1990, p. 55 (model illustrated)

119

**FADA RADIO AND ELECTRIC CO. INC. (FOUNDED 1920)**

Bullet Streamliner Radio

1940

yellow catalin case, red gumdrop knobs and blue dial bezel, with FADA label on face  
*height 6 1/4in (16cm); width 10in (25.5cm); depth 5 1/2in (14cm)*

**\$6,000 - 8,000**

Although the original All American 189 paper label is not present on base of case, the offered lot is in the Red, White and Blue style of the All American released in 1942 as a patriotic reaction to Pearl Harbor.

**Literature:**

John Sideli, 'Classic Plastic Radios of the 1930s and 1940s', E.P. Dutton, 1990, p. 69-70 (model illustrated)



118



119



120

120

**SEARS, ROEBUCK AND COMPANY  
(FOUNDED 1893)**

Silvertone Rocket Radio

1938

model 6111, off white enameled bakelite, dial  
marked 'Silvertone'

height 6 3/4in (17.14cm); length 12 1/4in  
(31.11cm); width 6 1/2in (16.51cm)

**\$1,000 - 1,500**



121

121

**HAROLD VAN DOREN (1895-1957)**

Air King 52 Skyscraper Radio

1933

for Air King Products Co. Inc., brown bakelite  
case with matching knobs and clock dial, dial  
marked 'Air King'

height 11 1/2in (29.21cm); width 8 3/4in  
(22.22cm); depth 7 1/2in (19cm)

**\$3,000 - 5,000**

**Literature:**

John Sideli, 'Classic Plastic Radios of the  
1930s and 1940s', E.P. Dutton, 1990, p. 6  
(model variant illustrated)

122 W

**BENJAMIN BOWDEN (1906-1998)**

Spacelander Bicycle

designed 1946, manufactured 1960

fiberglass, metal, plastic, rubber, leather, with  
two metal Bowden plaques

*height 41in (104cm); length 72 1/2in (184cm);*

*depth 23 1/2in (59cm)*

**\$10,000 - 12,000**



123

**ANTONIO DA ROS (1936-2012)**

Pair of Rare Clessidra Cilindrica Vases

1966

for Vetreria Gino Cenedese, sommerso glass

height 7in (17.5cm) to 8in (20cm)

**\$2,000 - 3,000**

**Provenance:**

Property from the Cenedese Archive

124

**ANTONIO DA ROS (1936-2012)**

Pair of Rare Clessidra Cilindrica Vases

1964

for Vetreria Gino Cenedese, sommerso glass, foil label to one example

'MURANO cenedese VETRI'

height 8 1/4in (21cm) to 9 1/4in (23.5cm)

**\$1,500 - 2,500**

**Provenance:**

Property from the Cenedese Archive



123



124





125

**ANTONIO DA ROS (1936-2012)**

Group of three Rare Clessidra Cilindrica Vases  
1964  
for Vetreria Gino Cenedese, sommerso glass  
height 8 1/2in (22cm) to 9 1/4in (23.5cm)

**\$2,500 - 3,500**

**Provenance:**

Property from the Cenedese Archive

126

**ANTONIO DA ROS (1936-2012)**

Two Rare Clessidra Quadrato Vases  
1964  
for Vetreria Gino Cenedese, sommerso glass  
heights 9 1/4in (23.5cm)

**\$2,000 - 3,000**

**Provenance:**

Property from the Cenedese Archive



125

126

127

**ANTONIO DA ROS (1936-2012)**

Pair of Rare Bottiglia Tipo Sasso con Collo Corto Vases

1965

for Vetreria Gino Cenedese, sommerso glass, the clear example with narrow band of internal decoration

*largest example height 14in (35.5cm)*

**\$2,000 - 3,000**

**Provenance:**

Property from the Cenedese Archive

128

**ANTONIO DA ROS (1936-2012)**

Rare Bottiglia Tipo Sasso con Collo Corto Vase

1965

for Vetreria Gino Cenedese, sommerso glass, the clear example with narrow band of internal decoration

*height 14 1/4in (36.1cm)*

**\$1,500 - 2,500**

**Provenance:**

Property from the Cenedese Archive



127



128

129

**ANTONIO DA ROS (1936-2012)**

Rare Large Clessidra a Tronco di Cono Vases  
1964

for Vetreria Gino Cenedese, dark smokey  
purple sommerso glass, cased in clear  
height 17 1/4in (44cm)

\$2,500 - 3,500

**Provenance:**

Property from the Cenedese Archive

130

**ANTONIO DA ROS (1936-2012)**

Rare Clessidra a Tronco di Cono Vase  
1964

for Vetreria Gino Cenedese, clear glass  
height 17 1/4in (44cm)

\$2,000 - 3,000

Approximately fewer than 50 examples of the  
present work were produced.

**Provenance:**

Property from the Cenedese Archive

131

**ANTONIO DA ROS (1936-2012)**

Rare Large Clessidra a Tronco di Cono Vase  
1964

for Vetreria Gino Cenedese, seville orange  
sommerso glass, cased in clear  
height 17 1/4in (44cm)

\$2,500 - 3,500

**Provenance:**

Property from the Cenedese Archive



129



130



131

132

**ANTONIO DA ROS (1936-2012)**

Rare Ovale Bocca Stretta Vase and Bowl

1963

for Vetreria Gino Cenedese, amber and olive green sommerso glass  
bowl height 8 1/4in (21cm); width 10in (25.5cm); vase height 12 1/4in  
(31cm)

**\$2,000 - 3,000**

**Provenance:**

Property from the Cenedese Archive

133

**ANTONIO DA ROS (1936-2012)**

Group of Four Rare Clessidra a Fungo Vases

1964

for Vetreria Gino Cenedese, sommerso glass  
height 5 1/2in (14cm) to 9 3/4in (25cm)

**\$4,500 - 6,500**

**Provenance:**

Property from the Cenedese Archive



134

**ANTONIO DA ROS (1936-2012)**

Three Flaconcino su Base Vases

1963

for Vetreria Gino Cenedese, glass, paper label to one example

'MURANO cenedese VETRI 8/63'

height 8in (20cm)

**\$1,500 - 2,000**

**Provenance:**

Property from the Cenedese Archive

135

**ANTONIO DA ROS (1936-2012)**

Three Flaconcino su Base Vases

1963

for Vetreria Gino Cenedese, glass, paper label to one example

'MURANO cenedese VETRI 8/63'

height 8in (20cm)

**\$1,500 - 2,000**

**Provenance:**

Property from the Cenedese Archive



134

135





136

136

**ANTONIO DA ROS (1936-2012)**

Two Rare Pesce con Murrine

1966

for Vetreria Gino Cenedese, murrine glass,  
large example engraved 'Cenedese'  
widths 11in (28cm); 4 3/4in (12cm)

**\$2,000 - 2,500**

This lot is offered with no reserve.

Approximately fewer than 20 examples of the  
present work were produced.

**Provenance:**

Property from the Cenedese Archive



137

137

**ANTONIO DA ROS (1936-2012)**

Two Rare Pesce Mulistrati

1963

for Vetreria Gino Cenedese, sommerso glass  
width 13 1/2in (34cm)

**\$3,200 - 5,200**

**Provenance:**

Property from the Cenedese Archive

138

**ANTONIO DA ROS (1936-2012)**

Two Rare Pesce Multistrati

1964

for Vetreria Gino Cenedese, sommerso glass  
widths 15 1/4in (39cm); 13 3/4in (35cm)

**\$3,000 - 5,000**

**Provenance:**

Property from the Cenedese Archive



138

139

**ANTONIO DA ROS (1936-2012)**

Two Rare Pesce Multistrati

1964

for Vetreria Gino Cenedese, sommerso glass  
width 13 1/2in (34cm)

**\$3,200 - 5,200**

**Provenance:**

Property from the Cenedese Archive



139



140

140

**ANTONIO DA ROS (1936-2012)**

Rare Gallo Multistrati con Bargigli  
1963

for Vetreteria Gino Cenedese, sommerso glass with trapped air bubbles  
*height 12 1/2in (32cm)*

**\$2,500 - 3,000**

Approximately fewer than 20 examples of the present work were produced.

**Provenance:**

Property from the Cenedese Archive



141

141

**ANTONIO DA ROS (1936-2012)**

Three Small Rare Gallina Rissosa Ciarliera  
1963

for Vetreteria Gino Cenedese, sommerso glass  
*heights 9 3/4in (25cm) to 15in (38cm)*

**\$2,500 - 3,500**

**Provenance:**

Property from the Cenedese Archive

142

**ANTONIO DA ROS (1936-2012)**

Rare Murrine Prototype Carafe  
1967

for Vetreteria Gino Cenedese, murrine glass, paper label 'MURANO  
cenedese VETRI 151/67'  
*height 9 1/4in (23.5cm)*

**\$1,000 - 1,500**

This lot is offered with no reserve.

Approximately fewer than 20 examples of the present work were produced.

**Provenance:**

Property from the Cenedese Archive



142



143

143

**ANTONIO DA ROS (1936-2012)**

Two Rare Prototype Murrine Vases  
1966

for Vetreria Gino Cenedese, murrine glass, paper label to large  
example 'CENEDESE GLASS MURANO 97/66 MADE IN ITALY'  
heights 13in (33cm); 9in (23cm)

**\$1,500 - 2,000**

Approximately fewer than 20 examples of the present work were  
produced.

**Provenance:**

Property from the Cenedese Archive

144

**ANTONIO DA ROS (1936-2012)**

Group of Four Rare Uccello Addormentato Art Pieces  
1964

for Vetreria Gino Cenedese, murrine glass  
heights 6 1/4in (16cm)

**\$2,200 - 2,700**

**Provenance:**

Property from the Cenedese Archive



144



145

145

**JULES OLITSKI (1922-2007)**

Untitled

2001

oil on paperboard, signed lower right and dated  
9 3/4 x 13 3/4in (25 x 34cm)

**\$4,000 - 6,000**

**Provenance:**

Collection of Barbara and Milford Nemer, Michigan

146 W

**PAUL LASZLO (1900-1993)**

Dining Table

circa 1950

blond wood

height 28 1/8in (71.4cm); width 57 1/2in (146cm); depth 58in  
(147.3cm)

**\$2,000 - 4,000**

**Provenance:**

Robert Willson, Los Angeles, California



146



147

**LINE VAUTRIN (1913-1997)**

Soleil a Pointes No. 2 Mirror

circa 1955

talosel incrustated with fragments of gilt mirror plate, engraved mark

'Line Vautrin' and 'RIN'

diameter 11 1/2in (29cm)

**\$10,000 - 15,000**

**Provenance:**

Jacqueline Subra, Paris

acquired from the above, 2000

148 W

**GIULIA VERONESI**

Pair of Perla Lounge Chairs

circa 1950

for I.S.A. Bergamo, upholstery, ebonized wood

height 34in (87cm); width 31in (79cm); depth 30in (76cm)

**\$3,000 - 5,000**

**Provenance:**

'The Ed Hardy San Francisco Collection', Bonhams, San Francisco,

May 5, 2009



147



148



149



150

149 <sup>W</sup>

**CLEVE GRAY (1918-2004)**

Flight of the Moth

1989

acrylic on canvas

inscribed on verso 'Gray, 89 and Flight of the Moth'

45 x 80in (115 x 203cm)

**\$8,000 - 12,000**

**Provenance:**

Irving Galleries, Palm Beach, Florida

Collection of Barbara and Milford Nemer, Michigan

150 <sup>W</sup>

**PAOLO BUFFA (1903-1970)**

Buffet

circa 1939

for Marelli & Colico, inlaid fruitwood, glass, brass

height 34 1/2in (87.5cm); width 67in (170cm); depth 17in (43cm)

**\$3,000 - 5,000**

**Provenance:**

Robert Willson, Los Angeles, California

**Literature:**

Roberto Rizzi, *I Mobili di Paolo Buffa*, Cantu, 2001, p. 40 - 41



151

151 <sup>W</sup>

**GIO PONTI (1891-1979)**

Extension Dining Table

1950s

for Singer & Sons, with two leaves

walnut, brass

height 29in (73.5cm); diameter 40in (101.5cm)

**\$2,000 - 3,000**

**Provenance:**

Robert Willson, Los Angeles, California

152 <sup>W</sup>

**HANS J. WEGNER (1914-2007)**

Valet Chair

1950s

for Johannes Hansen, oak, teak, brass branded 'JOHANNES HANSEN COPENHAGEN DENMARK'

height 37in (93cm); width 19 1/2in (49cm); depth 21in (53cm)

**\$4,000 - 6,000**

**Provenance:**

Private Collection, Seattle, Washington



152

153 W

**HANS J. WEGNER (1914-2007)**

Set of Eight W2 Dining Chairs

1950s

for C.M. Madsens, teak, leather, branded 'C.M. MADSENS FABRIKER

HAARBY DANMARK MADE IN DENMARK HANS J WEGNER'

height 30in (76cm); width 21 5/8in (55cm); depth 17in (43cm)

**\$2,000 - 3,000**

Noteworthy guests who have sat in these chairs include legendary reporters, publishers, architects as well as an ambassador that went on to be President of the United States.



154 <sup>W</sup>

**HANS J. WEGNER (1914-2007)**

Rare Music Stool

circa 1957

model AP30, for A.P. Stolen, teak, leather upholstery, underside with enamel tag 'DANISH FURNITURE MAKER'S CONTROL' and with ink stamp 13

height 20 1/2in (52cm); width 27 1/2in (70cm); depth 16in (41cm)

**\$1,500 - 2,000**



154

155 <sup>W</sup>

**FINN JUHL (1912-1989)**

Judas Extension Dining Table

designed 1953

for Niels Vodder, teak, silver

with two leaves, underside of table branded 'NIELS VODDER CABINETMAKER COPENHAGEN DENMARK DESIGN FINN JUHL'

height 28 3/4in (72.5cm); length excluding leaves 80in (203cm); width 55 1/2in (139.5cm)

**\$15,000 - 20,000**

The offered lot was acquired circa 1970 by the family of the present owner. Noteworthy guests who have shared a meal at this table include legendary reporters, publishers, architects as well as an ambassador that went on to be President of the United States.



155



156 W

**FRENCH MODERN**

Pair of Floor Lamps

circa 1960

leather, brass, steel, paper

height 69 1/2in (176.5cm); diameter 12in (30.5cm)

**\$3,500 - 5,500**

157 W

**CHARLES (1907-1978) & RAY EAMES (1912-1988)**

670 Lounge chair and 671 ottoman

designed 1956, for Herman Miller, laminated plywood, leather,

aluminum, with Black Herman Miller label

height of chair 31 3/4in (80cm); width 31 1/2in (80cm); depth 37 3/4in

(95cm); height of ottoman 16in (40cm); width 26in (66cm); depth 23

1/2in (59cm)

**\$2,000 - 3,000**

158 W

**CHARLES (1907-1978) & RAY EAMES (1912-1988)**

Eames Storage Unit 201

circa 1950

for Herman Miller, zinc coated steel, plywood

manufacturer's tag in top drawer

height 32 3/4in (83cm); width 46 3/4in (118cm); depth 16in (40cm)

**\$4,000 - 6,000**

**Provenance:**

Estate of Dr. Ruth Louise Mayer

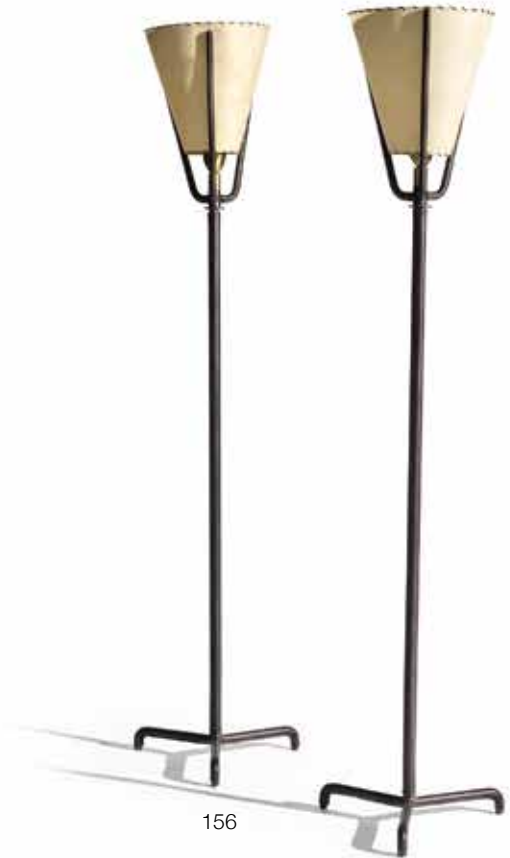

156



157



158

159 W

**SERGE MOUILLE (1922-1988)**

Single-Arm Pivoting Wall Light

circa 1955

designed 1953, for Ateliers Serge Mouille, enameled steel, enameled aluminum, brass

height 12 1/4in (31cm); width 25 5/8in (65cm); depth 7 1/2in (19cm)

**\$3,000 - 5,000**

**Provenance:**

Private Collection, Europe

**Literature:**

Christine and Alan Conour, 'Serge Mouille Luminaires', Le Regard d'Alan Editions, Paris, 1993, Unpaginated

160 W

**CHARLES (1907-1978) & RAY EAMES (1912-1988)**

Eames Storage Unit 270C

circa 1950

for Herman Miller, zinc coated steel, plywood, with Herman Miller tag in top drawer

height 32 1/2in (82cm); width 24in (60cm); depth 16 1/2in (41cm)

**\$3,000 - 5,000**

**Provenance:**

Estate of Dr. Ruth Louise Mayer

161 W

**CHARLES (1907-1978) & RAY EAMES (1912-1988)**

670 Lounge chair and 671 ottoman

1970-1990

designed 1956, for Herman Miller, laminated plywood, leather, aluminum, with Black Herman Miller label

height of chair 31 3/4in (80cm); width 31 1/2in (80cm); depth 37 3/4in (95cm); height of ottoman 16in (40cm); width 26in (66cm); depth 23 1/2in (59cm)

**\$2,000 - 3,000**



159



160



161



162 W

**WALTER LAMB**

Set of Outdoor Furniture

circa 1960

for Brown-Jordan, bronze tubing, cord, comprising: round coffee table, six armchairs, pair of lounge chairs, pair of ottomans, bench, rocking chair

*coffee table height 17 1/4in (43.8cm); diameter 38in (96.5cm)*

**\$12,000 - 15,000**



163 W

**DAN JOHNSON (1918-1979)**

Rare Gazelle Dining Table

circa 1955

bronze with Pompeian Verde patina, glass

height 29in (73.6cm), width 37 3/4in (96cm); depth 59 1/2in (151cm)

**\$8,000 - 12,000**





164

164

**PABLO PICASSO (1880-1972)**

Visage de Face (A.R. 454)

glazed earthenware, stamped, marked and numbered 'Madoura  
Empreinte Originale de Picasso 43/100'

height 2 1/2in (6.5cm); diameter 7in (18cm)

**\$1,500 - 2,000**

**To be sold without reserve**

**Provenance:**

Ziuta Gerstenzang Akston (1901-1994) and Joseph James Akston  
(1895-1983), Palm Beach, Florida  
Thence by Descent

165 W

**WALTER LAMB**

Chaise Lounge and Coffee Table

circa 1960

bronze tubing, glass

height of chaise 32in (81.2cm); length 62 3/4in (159.3cm); width 26  
1/2in (67.3cm); height of table 21 1/2in (54.6cm); width 25 1/2in  
(64.7cm); depth 25 1/2in (64.7cm)

**\$2,000 - 3,000**



165



166 W

**SOANE (FOUNDED 1997)**

Pair of Crillon Chairs

leather, steel, brass

height 32 1/4in (12.6cm); width 27 1/2in (10.8cm); depth 28 1/2in (11.2cm)

\$2,000 - 3,000

167 W

**ROGER CAPRON (FRENCH, BORN 1922)**

Coffee Table

1950s

wrought iron, tile

height 13in (33.02cm); length 40 1/16in (101.7cm); width 16 1/2in (41.9cm)

\$1,500 - 2,000

**Provenance:**

Robert Willson, Los Angeles, California



166



167



168

168

**ARNALDO POMODORO (BORN 1926)**

Untitled

1983

bronze with gold patina and steel laid on wood multiple, incised with the artist's signature and numbered 21/50 (there were also 8 artist's proofs), together with Sam Hunter's book, Arnaldo Pomodoro, published by Abbeville Press in 1982

*overall 12 3/8 x 12 3/8 x 1 3/4in (31.4 x 31.4 x 4.4cm)*

**\$3,000 - 5,000**

169

**BRUNO GAMBONE (BORN 1936)**

Vase

circa 1975

stoneware, painted 'BRUNO GAMBONE'

*height 13 1/2in (34.5cm); width 13in (33cm); depth 13in (33cm)*

**\$1,200 - 1,800**



169

170 W

**ITALIAN MODERN**

Coffee Table

1970s

lacquered parchment, brass, walnut stained wood

*height 14in (36cm); width 41 1/2in (105.3cm); depth 27 1/2in (70cm)*

**\$1,200 - 1,800**



170

171 W

**JULES WABBES (1919-1974)**

Desk and File Cabinet

circa 1970

mahogany, chrome plated steel, each handle stamped 'WABBES'  
*desk height 29 1/4in (74cm); width 71in (180cm); depth 30in (76cm);  
cabinet height 27in (68.5cm); width 23in (58.5cm); depth 20 1/2in  
(52cm)*

**\$6,000 - 8,000**





172

172 W

**CLAUDE VENARD (1913-1999)**

Untitled (Harbor Scene)

circa 1960

oil on canvas, signed lower right 'C. Venard'  
height 39 1/2in (100.5cm); width 39 3/4in  
(101cm)

**\$6,000 - 8,000**

173 W

**GEORGE NAKASHIMA (1905-1990)**

N12 Dining Table

1948

for Knoll Associates, walnut  
height 28 5/8in (72.6cm); length 54 1/4in  
(137.7cm); depth 32in (81.2cm)

**\$1,800 - 2,500**

**Provenance:**

Robert Willson, Los Angeles, California



173

174 W

**SERGE MOUILLE (1922-1988)**

Two Antony Wall Appliques

circa 1955

designed 1954 for Cité Internationale  
Universitaire, Antony, for Ateliers Serge  
Mouille, enameled steel, enameled aluminum,  
brass

height 16 3/4 (42.5cm); width 26in (66cm);  
depth 12in (30.5cm)

**\$4,000 - 6,000**

**Provenance:**

Private Collection, Europe

**Literature:**

Christine and Alan Conour, 'Serge Mouille  
Luminaires', Le Regard d'Alan Editions, Paris,  
1993, unpaginated



175 W

**ARNE NORELL (1917-1971)**

Pair of Ari Chairs

designed circa 1966

steel, leather

one chair bears metal tag Mobil AB Arne

Norell Made in Sweden ANEBY

height 30in (76.2cm); width 25 1/2in (64.7cm);

depth 38 1/2in (97.7cm)

**\$5,000 - 8,000**

174



175





176 W

**EDWIN SCHEIER (1910-2008)**

Totem

1960s

terracotta

*height 44in (111.7cm); diameter 10in (25.4cm)*

**\$5,000 - 8,000**

**Provenance:**

Collection of Dr. Albert Grokoest  
Robert Willson, Los Angeles, California

**Exhibited:**

'Edwin Scheier', The Currier Gallery of Art, Manchester, New  
Hampshire, 1966

177 W

**PEDRO FRIEDEBERG (BORN 1937)**

Aztec Clock

2000

mahogany stained wood, parcel gilt, signed in black ink 'PEDRO FRIEDEBERG', *together with* original artist's certificate  
*height 20 1/4in (51.4cm); width 20 1/2in (52.07cm); depth 12 1/2in (31.7cm)*

**\$3,500 - 4,500**

**Provenance:**

Pedro Friedeberg, Mexico City





178



179

178 W

**EDMONDO BACCI (1913-1978)**

Avvenimento

oil on canvas, signed, titled and annotated in black ink on verso  
'EDMONDO BACCI S. GREGORIO 198 VENEZIA AVVENIMENTO  
A35'

39 x 55in (99 x 139.8cm)

**\$8,000 - 12,000**

179 W

**ARTURO PANI (1915-1981)**

Cocktail Table

1950s

brass, slate

height 18 1/4in (46cm); width 38in (96.5cm); depth 38in (96.5cm)

**\$2,500 - 3,500**

**Provenance:**

Robert Willson, Los Angeles, California

180 W

**ARTURO PANI (1915-1981)**

Armchair

1940s

wrought-iron, hand caned

height 34 1/2in (87.5cm); width 26in (66cm); depth 22in (56cm)

**\$1,500 - 2,000**

**Provenance:**

Robert Willson, Los Angeles, California

181 W

**ARTURO PANI (1915-1981)**

Dining Table

circa 1960

wrought iron, marble

height 29in (73.6cm); length 76in (193cm); width 35 3/4in (90.8cm)

**\$3,000 - 5,000**

**Provenance:**

Robert Willson, Los Angeles, California



180



181

182 W

**MILO BAUGHMAN (1923-2003)**

Pair of Lounge Chairs

1970s

For Thayer Coggin, caned, chromed metal, upholstered  
one of the chairs tagged with Thayer Coggin fabric label  
*height 32 1/16in (81.4cm); width 30 1/4in (76.8cm); depth 35in (88.9cm)*

**\$2,500 - 3,500**

183 W

**PACE COLLECTION (FOUNDED 1960)**

Coffee Table

1970s

chromed steel, marble

*height 16 1/8in (40cm); width 41 3/4in (106cm); depth 53 3/4in (136cm)*

**\$2,000 - 3,000**

184 W

**MODERNIST**

Custom Lozenge Form Carpet

circa 1970

machine woven wool

*230 x 171in (584.2 x 434.34cm)*

**\$2,500 - 3,500**

**To be sold without reserve**

**Provenance:**

Ziuta Gerstenzang Akston (1901-1994) and Joseph James Akston (1895-1983), Palm Beach, Florida  
Thence by Descent

185 W

**PACE COLLECTION (FOUNDED 1960)**

Console

1970s

chromed steel, zebrawood

*height 29 5/8in (75cm); width 72 1/8in (183cm); depth 16in (40cm)*

**\$2,500 - 3,500**



182



183







184



185

186 W

**DIMITRI HADZI (1921-2006)**

Untitled

patinated bronze, inscribed with artist's signature and numbered 'III/IV'  
28 x 16 inches (71 x 41cm)

**\$4,000 - 6,000**

**Provenance:**

Estate of Donna G. Rosenberg, Winnetka, Illinois

187

**FREDDY TIMMS (1946-2017)**

Untitled

oil on canvas, signed in black ink on verso 'FREDDY TIMMS'  
24 x 31 1/2in (60 x 80cm)

**\$1,500 - 2,000**

**Provenance:**

Waringarri Aboriginal Arts  
Gallery Gondwana, Alice Springs, Australia  
Collection of Elaine Attias, Beverly Hills, California

188 W

**FINN JUHL (1912-1989)**

Bo-77 Two Tone Sofa

circa 1953

for Bovirke, teak, upholstery, enameled steel

height 30 3/4in (78.1cm); length 75 1/2in (191.7cm); depth 28 3/4in (73.02cm)

**\$2,500 - 3,500**

189 W

**SOREN GEORG JENSEN (1917-1982)**

Coffee Table

circa 1950

for Kubus, teak, tile, with Kubus tag on underside

height 17in (43cm); width 52 1/4in (133cm); depth 19in (49cm)

**\$1,000 - 1,500**

**Provenance:**

Private Collection, Northern California



186



187



188



189



(detail)

190

**JUNE SCHWARCZ (1918-2015) AND ARTHUR ESPENET  
CARPENTER (1920-2006)**

Jewelry Box

circa 1975

cherry, enamel, copper, etched on underside 'June Schwarz 557' and  
'Espenet 6808'

height 3 3/4in (9cm); width 12 1/4in (31cm); depth 10 1/4in (26cm)

\$3,000 - 5,000





191

191 W

**PHILIP MOULTROP (BORN 1947)**

Bowl

turned spalted red oak, inscribed 'PM Philip Moulthrop SPALTED RED OAK Quercus falcata 408-040'

*height 4 1/2in (11cm); diameter 19in (49cm)*

**\$1,000 - 1,500**

192 W

**GABRIEL KOHN (1910-1975)**

Untitled

circa 1960

laminated pine

*height 46in (117cm); width 36in (92cm); depth 14in (36cm)*

**\$2,000 - 4,000**

Gabriel Kohn's works are in the permanent collections of the Museum of Modern Art New York; Albright-Knox Art Gallery, Buffalo, New York; and Cranbrook Museum, Bloomfield Hills, Michigan



192



193 W

**BORGE MOGENSEN (1914-1972)**

Pair of Spanish Chairs

circa 1955

together with a Danish modern chaise longue, oak, leather

*height of chairs 26 1/2in (67cm); width 32 1/2in (83cm); depth 22in (56cm)*

**\$3,000 - 5,000**

**Provenance:**

Private Collection, Washington D.C.



194 W

**ROGER CAPRON (1922-2006)**

La Gorgonne

2001

enameled earthenware, metal base, signed in black 'R. CAPRON'; together with a copy of the original invoice from Hammer Galleries, New York

height 23 1/2in (60cm), width 17in (43cm), depth 7in (17.5cm)

**\$3,500 - 4,500**

**Provenance:**

Hammer Galleries, New York

Acquired from the above in 2002



194

195

**LISA LARSON**

Large Lion

circa 1965

for Gustavsberg, glazed earthenware, impressed 'LISA L. GUSTAVSBERG'

height 14in (36cm) width 15in (38cm); depth 16in (41cm)

**\$1,000 - 1,500**

**To be sold without reserve**

**Provenance:**

Ziuta Gerstenzang Akston (1901-1994) and Joseph James Akston

(1895-1983), Palm Beach, Florida

Thence by Descent



195

196

**BENJAMIN BUFANO (1890-1970)**

Hand of Peace

patinated bronze, enamel, wood, stamped 'Bufano' on reverse,  
stamped 'A/P' on underside of base  
overall height 15 1/2in (39.5cm); width of base 5in (13cm); depth of  
base 5in (13cm)

**\$1,500 - 2,500**



196

197

**BENJAMIN BUFANO (1890-1970)**

United in Peace

carved mahogany, unsigned  
height 18in (46cm); width 5in (13cm); depth 3in (8cm)

**\$4,000 - 6,000**



197

198 W

**CALIFORNIA STUDIO ARTIST**

Cactus Floor Lamp

1970s

wood

height 61 1/4in (155.5cm); diameter of base 13 3/4in (34.9cm)

**\$1,500 - 2,000**



198

199 W

**GIULIO PONTI AND GIUSEPPE TURCHINI (ATTRIBUTED TO)**

Lounge Chair

1960s

lacquered wood, upholstered

height 32in (81.2cm); width 29 1/2in (74.9cm); depth 36 1/2in (92.7cm)

**\$1,800 - 2,500**

**Provenance:**

Robert Willson, Los Angeles, California



199



200

200 W

**MOSHE KUPFERMAN (1926-2003)**

Untitled

1989

oil on paper, signed and dated in graphite (center right)

29 x 41in (74 x 104cm)

**\$2,000 - 3,000**

**Provenance:**

Collection of Elaine Attias, Beverly Hills, California

201 W

**LUTHER CONOVER (ACTIVE 1950S)**

Table

circa 1950

mahogany, iron

height 28 1/4in (71.7cm); length 68 1/2in (173.9cm); width 37in (93.9cm)

**\$1,500 - 2,000**



201



202 W

**ITALIAN MODERN**

Pair of Wall Lights

circa 1950

brass, enameled metal, frosted glass

height 19 3/4in (50cm); width 12in (30cm)

**\$1,500 - 2,000**

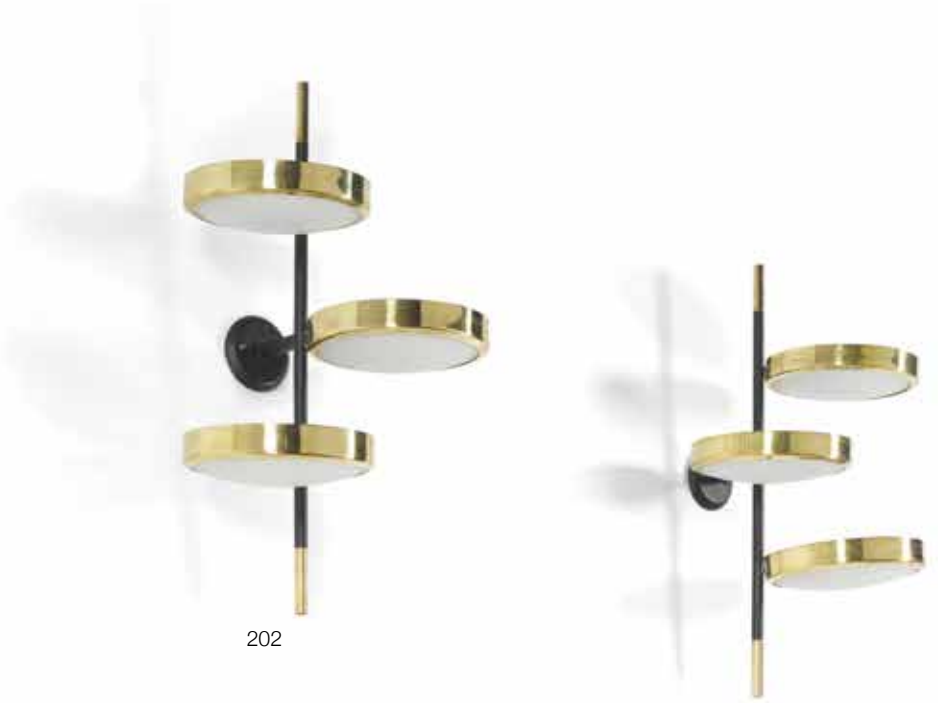

202

203 W

**WARREN PLATNER (1919-2006)**

Pair of Lounge Chairs

designed 1966

for Knoll Associates, nickel plated steel, wool upholstery

height 39in (99cm); width 40 3/4in (103.5cm); depth 28 3/4in (73cm)

**\$4,000 - 6,000**

204 W

**WARREN PLATNER (1919-2006)**

Coffee Table

designed 1966

for Knoll Associates, nickel plated steel, glass

height 14 3/4in (37.4cm); diameter 42in (106.6cm)

**\$800 - 1,200**



203

203

204

205 W

**SERGE MOUILLE (1922-1988)**

Agrafee Simple Lamp

circa 1960

designed 1956, for Ateliers Serge Mouille, enameled steel, enameled  
aluminum, brass

height 19in (49cm); width 12in (30cm); depth 20 3/4in (52.7cm)

**\$4,000 - 6,000**





206

206 W

**RICARDO MARTÍNEZ (1918-2009)**

Untitled

1963

oil on canvas, signed lower left 'Ricardo Martinez 63'  
17 7/8 x 21 3/4 in (45.4 x 55.2 cm)

**\$20,000 - 30,000**

We are grateful to the estate of the artist and the Fundación Ricardo Martínez for confirming the authenticity of this work.

207 W

**DUTCH**

Cleopatra Daybed

1950s

ebonized wood, upholstered

height 17 1/2in (44.4cm); length 78 1/4in (198.7cm); depth 32 3/4in (83.1cm)

**\$1,200 - 1,800**

**Provenance:**

Robert Willson, Los Angeles, California



207

208

**ROBERT GRAHAM (1938-2008)**

White Torso

circa 1992

for MOCA, bronze

height 11in (27.9cm); width 5in (12.7cm); depth 4 1/4in (10.7cm)

**\$1,500 - 2,500**

**Provenance:**

Robert Willson, Los Angeles, California

209 W

**FRANK LLOYD WRIGHT (1869-1959)**

Block

circa 1928

from the Biltmore Hotel, Phoenix, Arizona, concrete

length 13 1/2in (34cm); width 7in (17cm); depth 5in (12cm)

**\$1,500 - 2,000**



208



209



210

**GEORG JENSEN (1866-1935)**

Three Piece Group of Modernist Tableware

20th century

sterling silver, comprising a Blossom pattern vegetable dish, model 2E, 1925 - 1930, a Blossom pattern bread tray, model 2, 1933 - 1944, and a Rosebud pattern basket, model 235B, after 1945, all with the firm's hallmarks

*length of vegetable dish 13in (33cm); length of bread tray 11in (28cm); length of basket 5in (13cm)*

**\$2,000 - 3,000**

**Provenance:**

Private Collection, Northern California

211

**GEORG JENSEN (1866-1935)**

Bowl and Dish

mid 20th Century

sterling silver, bowl stamped 'Georg Jensen DENMARK STERLING 2A'; dish stamped 'X 10 DENMARK GEORG JENSEN STERLING 9255 2A'

*length of bowl 8in (20cm); diameter of dish 5in (13cm)*

**\$800 - 1,200**

**Provenance:**

Private Collection, Northern California

212

**DANISH AND AMERICAN MODERNIST**

Group of Four Table Objects

early/mid 20th century

sterling silver, comprising a Harald Nielsen for Georg Jensen pen tray, model 172; a Harald Nielsen for Georg Jensen bowl; model 624C; a Peter Smed bowl and an Evald Nielsen pitcher with ebony handle; each with respective hallmarks

*height of pitcher 8in (20cm); length of tray 6 1/2in (17cm)*

**\$2,500 - 3,500**

**Provenance:**

Private Collection, Northern California

213

**GEORG JENSEN (1866-1935)**

Covered Tureen

1915-1919

sterling silver, model 228, with the firm's hallmarks

*height 4in (10cm); diameter 9in (23cm)*

**\$2,000 - 3,000**

**Provenance:**

Private Collection, Northern California



210

211

214

**GUNDORPH ALBERTUS (1887-1970)**

Modernist Bowl

post 1945

for Georg Jensen, sterling silver, model 584A, stamped 'Dessin GA

DENMARK GEORG JENSEN STERLING 584A'

height of 4 1/2in (12cm); diameter 6in (15cm)

**\$1,200 - 2,000**

**Provenance:**

Private Collection, Northern California



212



213



214



215

215  
**HARALD NIELSEN (1892-1977)**  
Covered Blossom Bowl  
1915-1930  
for Georg Jensen, sterling silver, with Jensen maker's marks and designers stamp for Harald Nielson, pattern number '499'  
*height 3 1/2in (9cm); diameter 6in (15.4cm)*

**\$2,000 - 3,000**

**Provenance:**  
Private Collection, Northern California



216

217  
**GEORG JENSEN (1866-1935)**  
Two Handled Bowl  
mid 20th century  
sterling silver, stamped '925S DENMARK Georg Jensen & Wendel  
STERLING 625B'  
*height 3in (13cm); width 13in (33cm); diameter of interior 10in (26cm)*

**\$1,200 - 2,000**

**Provenance:**  
Private Collection, Northern California

216  
**GEORG JENSEN (1866-1935)**  
Salver and Serving Tray  
circa 1925  
sterling silver, salver stamped 'STERLING GEORG JENSEN 428C  
G 925 DENMARK'; tray stamped 'DENMARK GEORG JENSEN  
STERLING G 925 181 A'  
*diameter of salver 6in (15cm); length of tray 16in (41cm)*

**\$2,500 - 3,500**

**Provenance:**  
Private Collection, Northern California



217

218 W

**ELIZABETH GAROUSTE (BORN 1946) AND MATTIA BONETTI  
(BORN 1952)**

'Flowers in the Wood' Cabinet

1994

edited by David Gill, London, from an edition of 30 with 2 proofs and 2  
artist proofs, stained beech, silver plated bronze

height 71 1/2in (182cm); width 41 1/2in (105cm); depth 26 1/2in  
(67.5cm)

**\$8,000 - 12,000**

**Literature:**

Pierre Staudenmeyer, Nadia Croquet, Laurent Le Bon, 'Garouste &  
Bonetti', Editions Dis Voir, 1998, p.63 (model variant illustrated)





219



220



221

219 W

**PABLO SERRANO (1910-1985)**

Untitled

circa 1970

patinated and gilt bronze

height 22in (56cm); width 17in (43.25cm); depth 11in (28cm)

**\$3,000 - 5,000**

**To be sold without reserve**

**Provenance:**

Ziuta Gerstenzang Akston (1901-1994) and Joseph James Akston (1895-1983), Palm Beach, Florida

Thence by Descent

220

**ANDRÉ DERAÏN (1880-1954)**

Tête Triangulaire

patinated bronze, stamped and numbered 'ATELIER ANDRE DERAÏN 4/15'

height 7 1/2in (19cm); width 3in (7.6cm); depth 2 1/4in (5.7cm)

**\$2,500 - 3,500**

**Literature:**

Pierre Cailler, Catalogue Raisonné de l'oeuvre Sculpté de André Derain, Geneva, 1965, no. 4 (terracotta cast illustrated)

Pieter Coray, André Derain, Sculpteur, Exhibition Catalogue, Milan, 1994, no. 129, p. 119 (another cast illustrated)



221

**SOREL ETROG (1933-2014)**

Double Key Head

1969

bronze, stamped 'ETROG' and '6/10'

height 9in (23cm); width 7in (17.8cm); depth 3in (8cm)

**\$4,000 - 6,000**

**Provenance:**

Dominion Gallery, Montreal

Collection of Barbara and Milford Nemer, Michigan

222

**ROBERT SEYLE (BORN 1938)**

Nail Relief #52

1970, nails, wood

signed, titled and dated on verso

16in x 18in (41cm x 46cm)

**\$2,000 - 3,000**

**Provenance:**

Ankrum Gallery, Los Angeles, CA



222

223

**MARIO AGOSTINELLI (1915-2000)**

Brutalist Fish on Stand

circa 1970

patinated bronze, petrified fish, marble

overall height 12in (30cm); width 18in (46cm); depth 5in (13cm)

**\$2,000 - 3,000**

**To be sold without reserve**

**Provenance:**

Ziuta Gerstenzang Akston (1901-1994) and Joseph James Akston

(1895-1983), Palm Beach, Florida

Thence by Descent

224

**NORTHWEST COAST**

Skull Sculpture

1970s

carved wood

height 18in (45.7cm); width 9 1/4in (23.4cm); depth 11in (27.9cm)

**\$1,200 - 1,800**



223



224



225



226



227



228

225

**TONY DUQUETTE (1914-1999)**

Talisman of Power  
circa 1990  
amethyst, turquoise, quartz, vermeil, with original Tony Duquette box  
length 24 1/4in (61.5cm)

**\$3,000 - 5,000**

**Provenance:**

Private Collection, Malibu, California

226 W

**WILLIAM HAINES (1900-1973)**

Table Lamp  
circa 1955  
porcelain, lacquered wood  
height 33 1/2in (85cm); diameter of shade 17 1/8in (43.4cm)

**\$1,000 - 2,000**

**Provenance:**

Fuller + Roberts, Los Angeles, California

227 W

**TONY DUQUETTE (1914-1999)**

Faux Narwhal Tusk on Stand  
design introduced early 1970s  
resin, black metal  
overall height 92in (234cm); width of base 5in (13cm); depth of base 5in (13cm)

**\$800 - 1,200**

228 W

**TONY DUQUETTE (1914-1999)**

Phoenix Rising From Its Flames  
circa 1994  
resin, wood  
height 56 3/4in (144cm); width 28 1/2in (72cm); depth 14in (35cm)

**\$3,000 - 4,000**

The title of the offered lot is a metaphorical reference to the designer and his experience as a survivor of four fires.

**Exhibited:**

Los Angeles, Armand Hammer Museum, June 1994.

229 W

**FRENCH**

Garden Bench  
circa 1940  
for the Durenne foundry, France, patinated bronze  
height 36in (91cm); width 62in (158cm); depth 21in (53.5cm)

**\$5,000 - 7,000**

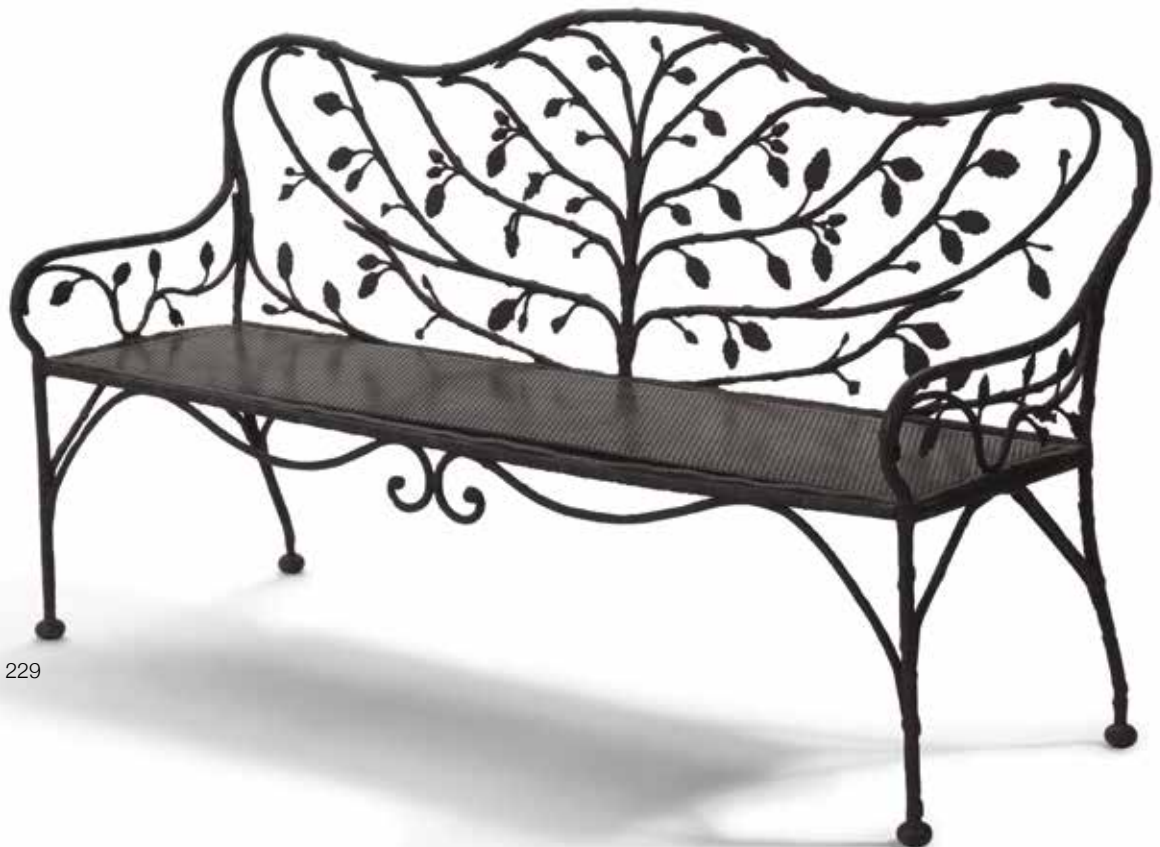

229



230

230

**ANTONIO DA ROS (1936-2012)**

Two Rare Clessidra Cilindrica Vases

1964

for Vetreria Gino Cenedese, one example blue and the other smoky green sommerso glass, each of slightly compressed cylindrical form  
*height blue example 11in (28cm); height smoky green example 15in (38cm)*

**\$2,000 - 3,000**

**Provenance:**

Property from the Cenedese Archive



231

231

**ANTONIO DA ROS (1936-2012)**

Rare Clessidra Ovale Vase

1964

for Vetreria Gino Cenedese, blue sommerso cased in clear  
*height 12in (30.5cm)*

**\$2,500 - 3,000**

**Provenance:**

Property from the Cenedese Archive



232

232

**VETRERIA GINO CENEDESE (FOUNDED 1946)**

Two Rare Coppa Piatta Molata Vases

1965

for Vetreria Gino Cenedese, sommerso glass, paper label to one example 'CENEDESE GLASS MURANO Campione Galli MADE IN ITALY' and foil label 'MURANO cenedese VETRI'

*largest height 7in (18cm); width 10in (25cm)*

**\$2,500 - 3,500**

Approximately fewer than 20 examples of the present work were produced.

The hand written word 'Campione' to the label on one example in the present lot refers to this example being a model upon which subsequent examples were based by the firm's glass blowers. Three dimensional models were more helpful than sketches for the glass blowers charged with replicating a new model.

The word 'Galli' refers to a popular retailer for works from the Cenedese workshop in Milan.

**Provenance:**

Property from the Cenedese Archive



233

233 W

**ANTONIO DA ROS (1936-2012)**

Three Rare Clessidra Cilindrica Vases

1964

for Vetreria Gino Cenedese, sommerso glass, paper label to large example 'MURANO cenedese VETRI 38/64'

*heights 5 1/2in (14cm) to 12in (30cm)*

**\$3,000 - 4,000**

**Provenance:**

Property from the Cenedese Archive



234 <sup>W</sup>

**ANTONIO DA ROS (1936-2012)**

Rare Vaso su Base Conica

1963-64

for Vetreria Gino Cenedese, green sommerso glass, cased in straw  
yellow

height 19 1/4in (49cm)

**\$2,500 - 3,500**

**Provenance:**

Property from the Cenedese Archive

235 <sup>W</sup>

**ANTONIO DA ROS (1936-2012)**

Rare Corolla Vase

1963-65

for Vetreria Gino Cenedese, red sommerso glass

height 14 1/2in (37cm)

**\$1,500 - 2,000**

**To be sold without reserve**

Approximately fewer than 20  
examples of the present work  
were produced.

**Provenance:**

Property from the Cenedese Archive



235

234

236 <sup>W</sup>

**ANTONIO DA ROS (1936-2012)**

Rare Pinnacolo Basso e Grasso

1963

for Vetreria Gino Cenedese, blue sommerso glass

cased in uranium glass

width 17 3/4in (45cm)

**\$2,500 - 3,000**

Approximately fewer than 20 examples of the present work were produced.

**Provenance:**

Property from the Cenedese Archive

237 <sup>W</sup>

**ANTONIO DA ROS (1936-2012)**

Three Rare Pinnacolo Vases

1963

for Vetreria Gino Cenedese, turquoise sommerso glass

cased in uranium glass

height 17in (43cm)

**\$2,500 - 3,000**

Approximately fewer than 20 examples of the present work were produced.

**Provenance:**

Property from the Cenedese Archive



236

237

237



238

238 W

**ANTONIO DA ROS (1936-2012)**

Group of Three Rare Litro Basso e Largo Vases

1963

for Vetreria Gino Cenedese, sommerso glass, paper label to one

example 'MURANO cenedese VETRI 22/63'

height 9in (22.5cm)

**\$2,000 - 3,000**

**Provenance:**

Property from the Cenedese Archive



239

239 W

**VETRERIA GINO CENEDESE (FOUNDED 1946)**

Three Rare Borraccia Ovale Vases

1965

for Vetreria Gino Cenedese, sommerso glass

heights 9 3/4in (25cm) to 10 1/2in (27cm)

**\$2,500 - 3,500**

**Provenance:**

Property from the Cenedese Archive

240 W

**ANTONIO DA ROS (1936-2012)**

Group of Three Rare Large Litro Basso e Largo Vases

1965

for Vetreria Gino Cenedese, sommerso glass, paper label to each

'MURANO cenedese VETRI / 59'

height 11 1/4in (28.5cm)

\$2,000 - 3,000

**Provenance:**

Property from the Cenedese Archive



241 W

**VETRERIA GINO CENEDESE (FOUNDED 1946)**

Rare Magma Vase

1976

for Vetreria Gino Cenedese, milky opalescent glass applied with silver oxides, paper label 'CENEDESE GLASS MURANO 3/76 MADE IN ITALY'

height 10 3/4in (27.5cm)

**\$2,200 - 2,800**

**Provenance:**

Property from the Cenedese Archive

242 W

**ANTONIO DA ROS (1936-2012)**

Large Rare Tulipano Chiuso Vase

1963

for Vetreria Gino Cenedese, green/yellow sommerso glass cased in green

height 15 1/2in (39.5cm)

**\$2,000 - 3,000**

**Provenance:**

Property from the Cenedese Archive



241



242



243 W

**ANTONIO DA ROS (1936-2012)**

Large Rare Tulipano Chiuso Vase

1963

for Vetreria Gino Cenedese, aquamarine sommerso glass cased in pale yellow

height 15 3/4in (40cm)

\$2,000 - 3,000

**Provenance:**

Property from the Cenedese Archive

244 W

**ANTONIO DA ROS (1936-2012)**

Large Rare Tulipano Chiuso Vase

1963

for Vetreria Gino Cenedese, blue sommerso glass cased in pale yellow

height 18 1/4in (46.5cm)

\$2,000 - 3,000

**Provenance:**

Property from the Cenedese Archive



243

244



245

245 W

**ANTONIO DA ROS (1936-2012)**

Group of Three Rare Clessidra a Lente Vases  
1964

for Vetreria Gino Cenedese, sommerso glass  
*height 7in (18cm)*

**\$2,500 - 3,500**

**Provenance:**

Property from the Cenedese Archive



246

246 W

**ANTONIO DA ROS (1936-2012)**

Two Rare Clessidra Alta Vases  
1964

for Vetreria Gino Cenedese, smokey sommerso glass and one  
example in clear glass, paper label to each 'MURANO cenedese  
VETRI'  
*smokey example height 12 1/4in (31cm); clear glass example 15in  
(38cm)*

**\$2,500 - 3,500**

**Provenance:**

Property from the Cenedese Archive

247 <sup>W</sup>

**ANTONIO DA ROS (1936-2012)**

Pair of Fasce Vases

1965

for Vetreria Gino Cenedese, red fasce cased in clear glass  
heights 7in (18cm); 7 1/2in (19cm)

**\$2,000 - 3,000**

To be sold without reserve

**Provenance:**

Property from the Cenedese Archive

248 <sup>W</sup>

**ANTONIO DA ROS (1936-2012)**

Pair of Rare Clessidra Cilindrica Vases

1966

for Vetreria Gino Cenedese, sommerso glass  
height 7in (17.5cm)

**\$2,000 - 3,000**

**Provenance:**

Property from the Cenedese Archive



247



248

249

**ALFREDO BARBINI (1912-2007)**

Unique Gruppo di due Figure

1949-50

for Vetreria Gino Cenedese, scavo glass with gold foil applications  
*figure height 12 1/2in (32cm); width 5 1/2in (14cm)*

**\$4,000 - 6,000**



249

250<sup>W</sup>

**ERMANNON NASON (1928-2013)**

Rare Asino and Mucca Iridata

1965

for Vetreria Gino Cenedese, iridescent glass  
*widths 9 3/4in (25cm); 11 1/2in (29cm)*

**\$2,000 - 3,000**

**Provenance:**

Property from the Cenedese Archive



250

251 <sup>W</sup>

**ANTONIO DA ROS (1936-2012)**

Three Bicchierone su Base a Campana con Bolla  
1966  
for Vetreria Gino Cenedese, sommerso glass  
heights 8 1/2in (22cm)

**\$3,000 - 4,000**

**Provenance:**

Property from the Cenedese Archive





252 W

**OSVALDO BORSANI (1911-1985)**

Pair of P110 Canada Chairs and an Ottoman  
designed 1966, executed 1970

for Tecno, laminated walnut, leather, plastic

*height of chairs 32in (82cm); width 31in (79cm); depth 36in (91cm);  
height of ottoman 17in (43.5cm); width 27in (69cm); depth 19in  
(49cm)*

**\$3,000 - 5,000**

**To be sold without reserve**

**Literature:**

Giampiero Bosoni, 'Osvaldo Borsani: Architect, Designer, Entrepreneur', Skira/Archivio Osvaldo Borsani, 2018, p. 435 (archive photograph of present lot in situ at La Ronda, 1971)

**Provenance:**

Ziuta Gerstenzang Akston (1901-1994) and Joseph James Akston (1895-1983), Palm Beach, Florida  
Thence by Descent



253 W

**OSVALDO BORSANI (1911-1985)**

D110 Canada Settee

designed 1966, executed 1970

for Tecno, laminated walnut, leather, plastic

height 32in (82cm); width 58in (148cm); depth 36in (91cm)

**\$2,000 - 3,000**

**To be sold without reserve**

**Literature:**

Giampiero Bosoni, 'Osvaldo Borsani: Architect, Designer, Entrepreneur', Skira/Archivio Osvaldo Borsani, 2018, p. 435 (archive photograph of present lot in situ at La Ronda, 1971)

**Provenance:**

Ziuta Gerstenzang Akston (1901-1994) and Joseph James Akston (1895-1983), Palm Beach, Florida

Thence by Descent



254 W

**ACHILLE (1918-2002) AND PIER GIACOMO (1913-1968) CASTIGLIONI**

Pair of Toio Floor Lamps  
designed 1962  
for Flos, iron, steel, car headlight  
height 64in (163cm)

**\$1,500 - 2,500**  
**To be sold without reserve**

**Literature:**

Piero Castiglioni, Chiara Baldacci, Giuseppe  
Blondo, 'Lux: Italia 1930-1990, l'Architettura  
della Luce', Berenice, 1991, p. 89

**Provenance:**

Ziuta Gerstenzang Akston (1901-1994) and  
Joseph James Akston (1895-1983), Palm  
Beach, Florida  
Thence by Descent

255 W

**ACHILLE (1918-2002) AND PIER GIACOMO (1913-1968) CASTIGLIONI**

Pair of Toio Floor Lamps  
designed 1962  
for Flos, iron, steel, car headlight  
height 64in (163cm)

**\$1,500 - 2,500**  
**To be sold without reserve**

**Provenance:**

Ziuta Gerstenzang Akston (1901-1994) and  
Joseph James Akston (1895-1983), Palm  
Beach, Florida  
Thence by Descent

256 W

**ACHILLE (1918-2002) AND PIER GIACOMO (1913-1968) CASTIGLIONI**

Early Toio Floor Lamp  
designed 1962  
iron, steel, car headlight  
height 64in (163cm)

**\$700 - 900**  
**To be sold without reserve**

**Provenance:**

Ziuta Gerstenzang Akston (1901-1994) and  
Joseph James Akston (1895-1983), Palm  
Beach, Florida  
Thence by Descent



257 W

**UMBERTO MARIANI (BORN 1936)**

La Cantertouriane Madonna: Il Potere  
Mistituatore

1968

oil on canvas, signed 'U. Mariani', dated '3-68'  
and titled  
overall 76 3/4in x 63 3/4in (195cm x 162cm)

**\$5,000 - 7,000**

**To be sold without reserve**

**Provenance:**

Ziuta Gerstenzang Akston (1901-1994) and  
Joseph James Akston (1895-1983), Palm  
Beach, Florida  
Thence by Descent

258 W

**GEORGE NELSON (1887-1978)**

Executive Desk

1950s

for Herman Miller, ebonized wood  
height 26in (66cm); width 80in (203.2cm);  
depth 36in (91.44cm)

**\$1,500 - 2,000**



257



258

259

**VENINI (FOUNDED 1921)**

Picture Frame

1940s

glass, brass, impressed 'MADE IN ITALY VENINI MURANO'  
height 13 1/2in (34cm); width 12in (30cm); depth 1/2in (2cm)

**\$1,000 - 1,500**

**To be sold without reserve**

**Provenance:**

Ziuta Gerstenzang Akston (1901-1994) and Joseph James Akston  
(1895-1983), Palm Beach, Florida  
Thence by Descent

260 W

**LUCIANO VISTOSI (BORN 1931)**

Set of Three Hurricane lanterns

circa 1970

glass, with Vistosi labels and tagged 'Made in Italy Murano'  
overall height 17in (42cm); diameter 7in (18cm)

**\$1,500 - 2,500**

**To be sold without reserve**

**Provenance:**

Ziuta Gerstenzang Akston (1901-1994) and Joseph James Akston  
(1895-1983), Palm Beach, Florida  
Thence by Descent



259



260



261 W

**LUCIANO VISTOSI (BORN 1931)**

Set of Three Hurricane Lanterns

circa 1970

glass, with Vistosi labels and tagged 'Made in Italy Murano'  
overall height 17in (42cm); diameter 7in (18cm)

**\$900 - 1,300**

**To be sold without reserve**

**Provenance:**

Ziuta Gerstenzang Akston (1901-1994) and Joseph James Akston  
(1895-1983), Palm Beach, Florida

Thence by Descent

262 W

**KPM**

Pair of Lamps

mid-20th century

porcelain, brass, with the firm's marks and stamped 'Made in  
Germany'

height 19in (49cm); width 10in (26cm); depth 10in (26cm)

**\$1,000 - 1,500**

**To be sold without reserve**

**Provenance:**

Ziuta Gerstenzang Akston (1901-1994) and Joseph James Akston  
(1895-1983), Palm Beach, Florida

Thence by Descent



261



262

263 <sup>W</sup>

**LUCIANO VISTOSI (BORN 1931)**

Pair of Large Munega Table Lamps

1971

for Vetreria Vistosi, hand-blown glass; together with a small Nessa table lamp, one with Vistosi label, each with 'Made in Murano' label  
*height 21in (53cm); width 17 1/2in (44cm)*

**\$3,000 - 5,000**

**To be sold without reserve**

**Literature:**

Charlotte and Peter Fiell, '1000 Lights 1960 to Present', Taschen, 2005, p. 286

**Provenance:**

Ziuta Gerstenzang Akston (1901-1994) and Joseph James Akston (1895-1983), Palm Beach, Florida  
Thence by Descent

264 <sup>W</sup>

**LUCIANO VISTOSI**

Pair of Zenda Ceiling Shades

circa 1970

glass, each with Vistosi label

*height 16in (41cm); greatest width 21in (54cm)*

**\$1,500 - 3,000**

**To be sold without reserve**

**Provenance:**

Ziuta Gerstenzang Akston (1901-1994) and Joseph James Akston (1895-1983), Palm Beach, Florida  
Thence by Descent



263



264

265 W

**VISTOSI**

Stacked Table Lamp

circa 1970

glass

*height 27in (69cm); diameter 15in (38cm)*

**\$800 - 1,200**

**To be sold without reserve**

**Provenance:**

Ziuta Gerstenzang Akston (1901-1994) and Joseph James Akston  
(1895-1983), Palm Beach, Florida

Thence by Descent



266 W

**VALERIA BORSANI AND ALFREDO BONETTI**

Two Seat Sofa

1971

model D120, designed 1966, for Tecno, upholstery, steel  
*height 22 1/2in (58cm); width 62in (157cm); depth 32in (82cm)*

**\$1,200 - 1,800**

**To be sold without reserve**

**Literature:**

Giampiero Bosoni, 'Osvaldo Borsani: Architect, Designer, Entrepreneur', Skira/Archivio Osvaldo Borsani, 2018, p. 536

**Provenance:**

Ziuta Gerstenzang Akston (1901-1994) and Joseph James Akston (1895-1983), Palm Beach, Florida  
Thence by Descent

267 W

**PHILIP (1907-1987) AND KELVIN LAVERNE (BORN 1937)**

Chan Coffee Table

circa 1965

acid-etched, enameled and patinated bronze, acid-etched facsimile signature 'PHILIP + KELVIN LAVERNE'  
*height 15 3/4in (6.2cm); width 23 1/16in (9cm); length 70 1/8in (27.6cm)*

**\$4,000 - 6,000**

268 W

**ALFONSO GOMEZ BONIFACIO (1933-2011)**

Elorador

1969

oil on canvas, signed lower right 'Bonifacio 69' and further inscribed on verso 'Bonifacio 69 TAMANO 170 x 130 Titulo Elorador'  
*overall height 67 1/2in (171.5cm); width 51 3/4in (131.5cm)*

**\$2,000 - 3,000**

**To be sold without reserve**

**Provenance:**

Galeria Juana Mordo, Madrid

Ziuta Gerstenzang Akston (1901-1994) and Joseph James Akston (1895-1983), Palm Beach, Florida  
Thence by Descent

269 W

**VALERIA BORSANI AND ALFREDO BONETTI**

Four Seat Sofa

1971

designed 1966, for Tecno, upholstery, steel  
*height 24 1/2in (62.2cm); width 112 1/2in (285.7cm); depth 34in (86.3cm)*

**\$1,500 - 2,500**

**To be sold without reserve**

**Provenance:**

Ziuta Gerstenzang Akston (1901-1994) and Joseph James Akston (1895-1983), Palm Beach, Florida  
Thence by Descent



266



267



268



269



270 <sup>W</sup>

**VALERIA BORSANI AND ALFREDO BONETTI**

Pair of Modular Chairs

1971

designed 1966, for Tecno, upholstery, steel

height 20in (51cm); width 29in (74cm); depth 29in (74cm)

**\$1,200 - 1,800**

**To be sold without reserve**

**Literature:**

Giampiero Bosoni, 'Osvaldo Borsani: Architect, Designer, Entrepreneur', Skira/Archivio Osvaldo Borsani, 2018, p. 536

**Provenance:**

Ziuta Gerstenzang Akston (1901-1994) and Joseph James Akston (1895-1983), Palm Beach, Florida  
Thence by Descent

271 <sup>W</sup>

**JACQUES QUINET (1918-1992)**

Pair of low tables

1960s

for Broncz, gilt bronze, glass

each stamped 'BRONCZ' and with facsimile signature

height 14in (35cm); width 39 1/2in (100.5cm); depth 20in (50.5cm)

**\$2,500 - 3,500**

**Provenance:**

Robert Willson, Los Angeles, California

272 <sup>W</sup>

**EERO SAARINEN (1910-1961)**

Tulip Coffee Table

designed circa 1956

for Knoll Associates, powder coated aluminum, marble

height 14 1/4in (36.1cm); diameter of table top 36in (91.4cm)

**\$1,000 - 1,500**

**To be sold without reserve**

**Provenance:**

Ziuta Gerstenzang Akston (1901-1994) and Joseph James Akston (1895-1983), Palm Beach, Florida  
Thence by Descent





272

273 W

**EERO SAARINEN (1910-1961)**

Pair of Tulip Occasional Tables  
designed circa 1956  
for Knoll Associates, powder coated aluminum, marble  
height 20 1/2in (52cm); diameter 16in (41cm)

**\$1,000 - 1,500**

**To be sold without reserve**

**Provenance:**

Ziuta Gerstenzang Akston (1901-1994) and Joseph James Akston  
(1895-1983), Palm Beach, Florida  
Thence by Descent

274 W

**EERO SAARINEN (1910-1961)**

Pair of Tulip Occasional Tables  
designed circa 1956  
for Knoll Associates, powder coated aluminum, marble  
height 20 1/2in (52cm); diameter 16in (41cm)

**\$1,000 - 1,500**

**To be sold without reserve**

**Provenance:**

Ziuta Gerstenzang Akston (1901-1994) and Joseph James Akston  
(1895-1983), Palm Beach, Florida  
Thence by Descent



273



274



275 W

**MURANO**

Vase

1950s

glass

height 15 1/2in (39.4cm); width 6 1/4in (15.9cm);

depth 3 1/2in (8.3cm)

**\$1,500 - 2,000**

**Provenance:**

Fifty/50, New York

276

**FULVIO BIANCONI (1915-1996)**

A Macchie Bottle

for Venini, glass, engraved 'Venini Italia' on underside

height 4 3/4in (12cm); diameter 4in (10.1cm)

**\$2,000 - 3,000**



275



276

277

**CARLO SCARPA**

Sommerso a Bollicine bowl

Circa 1936

for Venini, acid etched 'venini murano'

height 2 1/2in (6.5cm); width 3 1/2in (9cm); depth 2 1/2in (6.5cm)

**\$2,000 - 3,000**

**Provenance:**

Private Collection, United Kingdom



277

278

**GIORGIO FERRO**

Volante Pitcher

1950s

for A.V.E.M., iridized glass

height 5 1/2in (14cm)

**\$3,000 - 5,000**



278

279 W

**TOMMI PARZINGER (1930-1991)**

Pair of Floor Lamps  
circa 1950  
brass, enameled metal  
height 61 1/4in (156cm)

**\$2,000 - 3,000**  
To be sold without reserve

**Literature:**

Giampiero Bosoni, 'Osvaldo Borsani: Architect, Designer, Entrepreneur', Skira/ Archivio Osvaldo Borsani, 2018, p. 435 (archive photograph of present lot in situ at La Ronda, 1971)

**Provenance:**

Ziuta Gerstenzang Akston (1901-1994) and Joseph James Akston (1895-1983), Palm Beach, Florida  
Thence by Descent

280 W

**TOMMI PARZINGER (1930-1991)**

Pair of Floor Lamps  
circa 1950  
brass, enameled metal  
height 61 1/4in (156cm)

**\$2,000 - 3,000**  
To be sold without reserve

**Provenance:**

Ziuta Gerstenzang Akston (1901-1994) and Joseph James Akston (1895-1983), Palm Beach, Florida  
Thence by Descent

281 W

**ALDO TURA (1909-1963)**

Bar Trolley, Ice Bucket and Pitcher  
1960s  
lacquered parchment, brass  
height of trolley 29 1/2in (75cm); length 29 1/2in (75cm); depth 17in (44cm); height of ice bucket 12 1/2in (32cm); width 7in (18cm); depth 7in (18cm)

**\$2,000 - 3,000**  
To be sold without reserve

**Provenance:**

Ziuta Gerstenzang Akston (1901-1994) and Joseph James Akston (1895-1983), Palm Beach, Florida  
Thence by Descent





282 W

**EUGENIO GERLI (1923-2013)**

Custom D142 A/B Clamis Sofa  
designed 1969, executed 1970  
for Tecno, upholstery, metal  
*height 26in (66cm); width 104in (264cm);  
depth 48in (122cm)*

**\$1,500 - 2,000**

**To be sold without reserve**

**Literature:**

Giampiero Bosoni, 'Osvaldo Borsani:  
Architect, Designer, Entrepreneur', Skira/  
Archivio Osvaldo Borsani, 2018, p. 533

**Provenance:**

Ziuta Gerstenzang Akston (1901-1994) and  
Joseph James Akston (1895-1983), Palm  
Beach, Florida  
Thence by Descent

283 W

**PHILIP AND KELVIN LAVERNE**

Chan Coffee Table  
circa 1965  
acid-etched, enameled and patinated  
bronze, acid-etched facsimile signature  
'PHILIP + KELVIN LAVERNE'  
*height 17in (6.6cm); diameter 47 1/4in  
(18.6cm)*

**\$5,000 - 7,000**



282

283



284

284 W

**MIKLOS BORSOS (1906-1990)**

Abstract Bust on Pedestal

1965

marble, black acrylic, sculpture incised 'Borsos M 1965'

height of sculpture 18 1/4in (47.5cm); width 26 1/2in (75cm); depth 4 1/4in (11in); height of pedestal 41 1/4in (105cm); width 12in (31cm); depth 9 1/4in (23.5cm)

**\$2,000 - 3,000**

**To be sold without reserve**

**Provenance:**

Ziuta Gerstenzang Akston (1901-1994) and Joseph James Akston (1895-1983), Palm Beach, Florida

Thence by Descent

285 W

**EMILIO GRECO (1913-1995)**

Figura Accolata

1956

bronze, white base, signed 'GRECO', edition 3/3

26 x 19 1/2in (66 x 49.5cm)

**\$4,000 - 6,000**

**Provenance:**

Collection of Elaine Attias, Beverly Hills, California



285

286 W

**ITALIAN MODERN**

Brutalist Sculpture

circa 1970

patinated and gilt bronze, marble base, inscribed 'Broglia'  
overall height 25in (63.5cm); width 29in (73.6cm); depth 20 1/2in (52cm)

**\$2,000 - 3,000**

To be sold without reserve

**Provenance:**

Ziuta Gerstenzang Akston (1901-1994) and Joseph James Akston (1895-1983), Palm Beach, Florida

Thence by Descent

287 W

**PHILIP AND KELVIN LAVERNE**

Chan Li Low Table

circa 1965

acid-etched, enameled and patinated bronze, acid-etched facsimile signature 'PHILIP + KELVIN LAVERNE'

height 17 1/4in (43cm); length 47 1/2in (120cm); depth 23 1/4in (59cm)

**\$3,000 - 5,000**



286



287



288



289

288 W

**ROLANDO ROJAS (BORN 1970)**

Quatro Personajes  
oil on canvas  
height 60 1/2in (153.6cm); width 40 3/4in (103.5cm); depth 2in (5.08cm)

**\$8,000 - 12,000**

289 W

**KARL SPRINGER (1931-1991)**

Console Table  
1970s  
leather, aluminum  
height 36in (91cm); width 65in (165cm); depth 24in (61cm)

**\$4,000 - 6,000**

**To be sold without reserve**

**Provenance:**

Ziuta Gerstenzang Akston (1901-1994) and Joseph James Akston (1895-1983), Palm Beach, Florida  
Thence by Descent

290 W

**EUGENIO GERLI (1923-2013)**

Pair of PS142 Lounge Chairs  
circa 1966  
for Tecno, upholstery, chromed metal  
height 26 1/2in (67cm); width 26 1/2in (67cm); depth 24in (61cm)

**\$1,000 - 1,500**

**To be sold without reserve**

**Provenance:**

Ziuta Gerstenzang Akston (1901-1994) and Joseph James Akston (1895-1983), Palm Beach, Florida  
Thence by Descent

291 W

**EUGENIO GERLI (1923-2013)**

Pair of PS142 Lounge Chairs  
circa 1966  
for Tecno, upholstery, chromed metal  
height 26 1/2in (67cm); width 26 1/2in (67cm); depth 24in (61cm)

**\$1,000 - 1,500**

**To be sold without reserve**

**Provenance:**

Ziuta Gerstenzang Akston (1901-1994) and Joseph James Akston (1895-1983), Palm Beach, Florida  
Thence by Descent

292 W

**PHILIP (1907-1987) AND KELVIN LAVERNE (BORN 1937)**

Chan Boucher Coffee Table  
circa 1965  
acid-etched, enameled and patinated bronze, acid-etched facsimile signature 'PHILIP + KELVIN LAVERNE'  
height 16 1/2in (42cm); width 60 1/2in (154cm); depth 31 1/2in (80cm)

**\$4,200 - 5,500**

Please note: a detail of the top of this lot is illustrated online.



290



291



292





293

293 W

**GEORGE ERNSTSON (1945-2011)**

Untitled (Yellow and Black Totem Sculpture)

2004

anodized aluminum and plexiglass

height 11 1/2in (29.2cm); width 23 3/4in (60.3cm); depth 6in (15.2cm)

**\$3,000 - 5,000**

294 W

**JEAN-MARIE FIORI (BORN 1952)**

Bull's Bench

patinated bronze, signed, numbered 'EA II' and with Deroyauime foundry mark

11 x 96 1/2 x 33 1/2in (28 x 245 x 85cm)

**\$4,000 - 6,000**

295 W

**GEORGE ERNSTSON (1945-2011)**

(Untitled) Black Zig-Zag Wave

1994

wood, fiberglass, resin, lacquer, and polyurethane

length 78 1/4in (198.7cm); width 16in (40.6cm); depth 2 1/2in (6.3cm)

**\$5,000 - 7,000**

296 W

**GAETANO PESCE (BORN 1939)**

Feltri Armchair

circa 1987

for Cassina, cotton, felt, resin

height 33in (83.8cm); width 48in (122cm); depth 35in (89cm)

**\$1,200 - 1,800**



294



295



296

297 W

**MARCO FANTONI**

Set of Three Tables

1971

for Tecno, patinated metal, leather

*height of largest table 16in (41cm); width 23in (59cm); depth 23 1/2in (60cm), height of smaller tables 14 1/2in (37cm); width 21in (53cm); depth 11 1/2in (29cm)*

**\$2,000 - 3,000**

**To be sold without reserve**

**Provenance:**

Ziuta Gerstenzang Akston (1901-1994) and Joseph James Akston (1895-1983), Palm Beach, Florida

Thence by Descent



297

298 W

**VAL BERTOIA (BORN 1949)**

Sounding Sculpture (B-2189)

2018

with 49 rods, bronze, beryllium copper, brass

height 41in (104cm); width of base 11in (28cm); depth of base 11in (28cm)

**\$4,000 - 6,000**

The offered lot is accompanied by a letter of authenticity from Val Bertoia



298

299 W

**OSVALDO BORSANI (1911-1985)**

Set of Twelve Modus Stacking Dining Chairs

designed 1972, executed 1972

for Tecno, plastic, aluminum, steel, molded signature 'Tecno' and 'SM 203'

height 28in (71.1cm); width 20 3/4in (22.5cm); depth 18 1/2in (47cm)

**\$1,500 - 2,500**

**To be sold without reserve**

**Literature:**

Giampiero Bosoni, 'Osvaldo Borsani: Architect, Designer, Entrepreneur', Skira/Archivio Osvaldo Borsani, 2018, p. 512

**Provenance:**

Ziuta Gerstenzang Akston (1901-1994) and Joseph James Akston (1895-1983), Palm Beach, Florida  
Thence by Descent



299

300 W

**VLADIMIR KAGAN (1927-2016)**

Pair of Nightstands

1970s

walnut, acrylic

height 18 3/4in (7.3cm); width 24in (9.4cm); depth 18 1/4in (7.1 cm)

**\$4,000 - 6,000**

301 W

**VLADIMIR KAGAN (1927-2016)**

Sideboard

1970s

walnut, acrylic

height 32in (12.5cm); length 72in (28.3cm); depth 20 1/4in (7.9cm)

**\$7,000 - 9,000**



300



301



302 W

**EVELYN ACKERMAN (1924-2012)**

Bird Tapestry  
for ERA INDUSTRIAS, hand hooked wool, wood, metal chain, with  
ERA tag on reverse  
10 x 56in (26 x 143cm)

**\$800 - 1,200**

**Provenance:**

Private Collection, Northern California

303 W

**VLADIMIR KAGAN (1927-2016)**

Pair of Swiveling Crescent Chairs  
circa 1970  
acrylic, upholstery  
height 25 1/2in (65cm); width 29 1/2in (75cm); depth 30in (76cm)

**\$3,000 - 5,000**

**To be sold without reserve**

**Provenance:**

Ziuta Gerstenzang Akston (1901-1994) and Joseph James Akston  
(1895-1983), Palm Beach, Florida  
Thence by Descent

304 W

**VLADIMIR KAGAN (1927-2016)**

Pair of Swiveling Crescent Chairs  
circa 1970  
acrylic, upholstery  
height 25 1/2in (65cm); width 29 1/2in (75cm); depth 30in (76cm)

**\$3,000 - 5,000**

**To be sold without reserve**



302



303

304

305 W

**FRENCH MODERN**

Custom Display Tower

brass, cherry, glass

height 76 3/4in (194.9cm); width 19 1/2in (49.5cm); depth 19 1/2in (50.1cm)

**\$1,500 - 2,000**

306 W

**FRENCH MODERN**

Custom Display Tower

brass, cherry, glass

height 76 3/4in (194.9cm); width 19 1/2in (49.5cm); depth 19 3/4in (50.1cm)

**\$1,500 - 2,000**

307 W

**FRENCH MODERN**

Custom Vitrine

brass, cherry, glass

height 65 5/8in (166.6cm); width 37 1/2in (95.2cm); depth 11 3/4in (29.8cm)

**\$2,000 - 3,000**

308 W

**ANTONIO SAURA (1930-1998)**

Tapestry

circa 1960

wool, with fabric label on the reverse, 'Saura Carola- Torres'  
102 x 82in (259 x 208.5cm)

**\$8,000 - 12,000**

To be sold without reserve

**Provenance:**

Ziuta Gerstenzang Akston (1901-1994) and Joseph James Akston

(1895-1983), Palm Beach, Florida

Thence by Descent

309 W

**VLADIMIR KAGAN (1927-2016)**

Omnibus Sofa

1970s

in four parts, acrylic, upholstery

height 26in (66.04cm); depth 60in (152.4cm); length 207in (525.7cm)

**\$5,000 - 7,000**



305



306



307

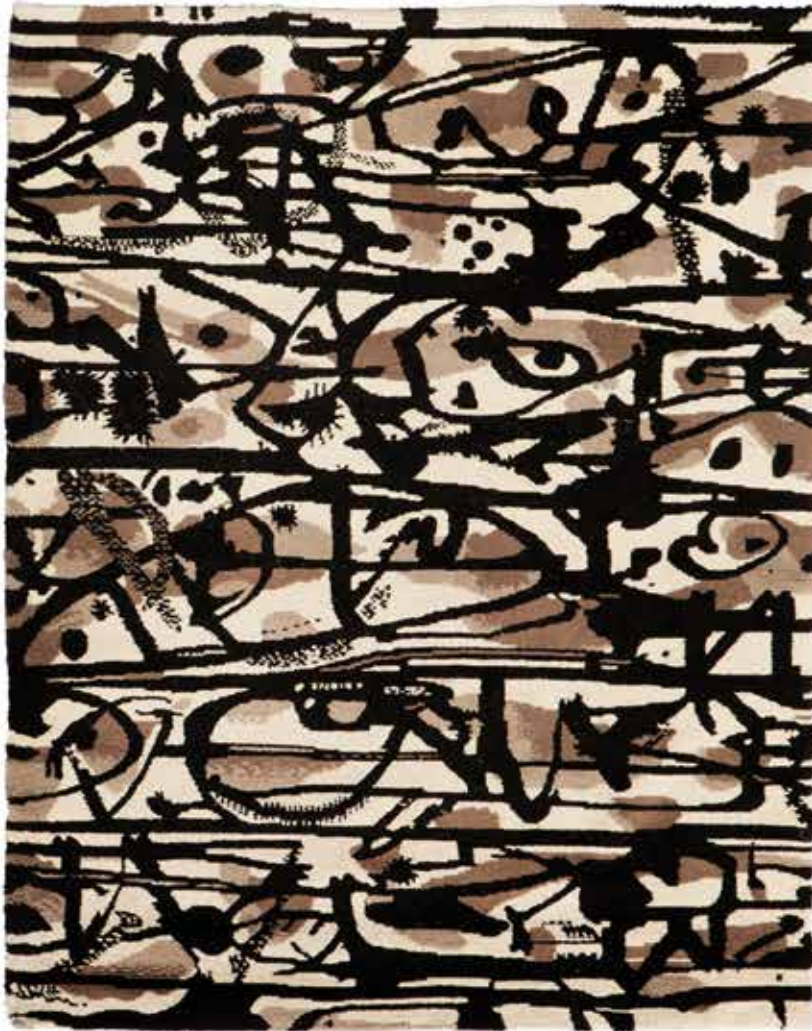

308



309

310 W

**EUGENIO GERLI (1923-2013)**

Pair of P142 Lounge chairs and Ottomans  
designed 1969, executed 1970  
for Tecno, upholstery, chromed metal  
*height of chairs 26in (66cm); width 30in (76cm); depth 30in (76cm),  
height of ottomans 13in (33cm); diameter 18in (46cm)*

**\$1,500 - 2,500**

**To be sold without reserve**

**Literature:**

Giampiero Bosoni, 'Osvaldo Borsani: Architect, Designer,  
Entrepreneur', Skira/Archivio Osvaldo Borsani, 2018, p. 533

**Provenance:**

Ziuta Gerstenzang Akston (1901-1994) and Joseph James Akston  
(1895-1983), Palm Beach, Florida  
Thence by Descent





311

**ANGELO MANGIAROTTI (1921-2012)**

Two Vases

1971

for Vistosi, molded glass

*largest example height 2 1/2in (6.5cm); width 8 3/4in (22cm)*

**\$1,500 - 2,000**

**To be sold without reserve**

**Provenance:**

Ziuta Gerstenzang Akston (1901-1994) and Joseph James Akston (1895-1983), Palm Beach, Florida

Thence by Descent

312

**ANGELO MANGIAROTTI (1921-2012)**

Two Vases

1971

for Vistosi, molded glass

*largest example height 2 1/2in (6.5cm); width 8 3/4in (22cm)*

**\$1,500 - 2,000**

**To be sold without reserve**

**Provenance:**

Ziuta Gerstenzang Akston (1901-1994) and Joseph James Akston (1895-1983), Palm Beach, Florida

Thence by Descent





313 W

**BRUNO MATHSSON**

Jetson Lounge Chair

circa 1969

for Dux, vinyl, chromed steel

height 38in (97cm); width 25in (64cm); depth 36in (91cm)

**\$800 - 1,200**

**Provenance:**

Private Collection, California



313

314 W

**PIET HEIN EEK (BORN 1967)**

Bench

circa 2012

from the 'Waste' series, reclaimed steel

height 18 3/4in (48cm); width 43 1/4in (110cm); depth 16in (41cm)

**\$1,000 - 1,500**



314

315 W

**BRUNO MATHSSON**

Pair of Jetson Lounge chairs

circa 1969

for Dux, vinyl, chromed steel

one chair marked 'Bruno Mathsson' and 'Made by Dux'  
height 38in (97cm); width 25in (64cm); depth 36in (91cm)

**\$1,800 - 2,500**

**Provenance:**

Private Collection, California

316 W

**MAN RAY (1890-1976) AND DINO GAVINA (1922-2007)**

Le Témoin

1971

for Gavina, acrylic, plywood, faux leather, foam

height 27 1/2in (70cm); width 58in (147.5cm); depth 16 1/2in (43cm)

**\$1,500 - 2,000**



315



316



317



318

317 W

**IDA RITTENBERG KOHLMAYER (1912-1997)**

Untitled (Pink Painting)

1985

oil and mixed media on canvas, signed and dated lower right  
'Kohlmeyer 85'

67 1/2 x 67 1/2in (172 x 172cm)

**\$25,000 - 35,000**

**Provenance**

Collection of Barbara and Milford Nemer, Michigan

318 W

**STUDIO BBPR (FOUNDED 1932)**

SPAZIO Work Table

1950s

for Olivetti, leather, enamel, metal

height 30 1/2in (77.5cm); width 76in (193cm); depth 31in (79cm)

**\$1,800 - 2,500**

319 W

**IDA KOHLMAYER (1912-1997)**

Untitled

1995

painted aluminum, signed and dated on underside 'Kohlmeyer 1995'  
height 87in (220cm); width 36in (91cm); depth 19in (48cm)

**\$12,000 - 18,000**



319

320

**MODERNIST**

Geometric Sculpture  
circa 1970  
lucite

*height 16in (40.7cm); width 13in (33cm); depth 2 1/8in (5.2cm)*

**\$1,000 - 1,500**

**To be sold without reserve**

**Provenance:**

Ziuta Gerstenzang Akston (1901-1994) and Joseph James Akston  
(1895-1983), Palm Beach, Florida  
Thence by Descent

321

**ELEANORE PEDUZZI RIVA**

Rare Set of Three Graduated Stacking Pomeri Bowls  
1970

opalescent glass

*overall height 4in (10cm); greatest diameter 10in (26cm)*

**\$1,500 - 2,000**

**To be sold without reserve**

**Provenance:**

Ziuta Gerstenzang Akston (1901-1994) and Joseph James Akston  
(1895-1983), Palm Beach, Florida  
Thence by Descent



320



321



322

**VASA VELIZAR MIHICH (BORN 1933)**

Untitled (Sphere)

1979

acrylic, etched '1620 G 75 Vasa 79'

diameter 5in (13cm)

**\$2,000 - 3,000**

**To be sold without reserve**

**Provenance:**

Ziuta Gerstenzang Akston (1901-1994) and Joseph James Akston  
(1895-1983), Palm Beach, Florida

Thence by Descent



322

323

**VASA VELIZAR MIHICH (BORN 1933)**

Untitled (Sphere on Stand)

1973

acrylic, etched 'Vasa 73'

height with stand 10 1/2in (26cm); diameter 9 1/4in (23cm)

**\$2,000 - 3,000**



323



324



325



326

324

**GERALD LAING (1936-2011)**

Rhodium Trace

1968

rhodium plated brass, plexiglas, marble, incised on base 'RHODIUM TRACE NYC 1968 Gerald Laing 4/10'

height 13in (33.02cm); width 7 1/16in (17.9cm); depth 3 1/8in (7.9cm)

**\$2,000 - 3,000**

325

**ILYA BOLOTOWSKY (1907-1981)**

Untitled

circa 1965

acrylic on wood, signed in black 'Ilya Bolotowsky'

height 13 3/4in (35cm); width 2in (5cm); depth 2in (5cm)

**\$2,000 - 3,000**

**Provenance:**

Albert Goldman Gallery, Florida

Eric Collins, Delaware

Beth Urdang Fine Art, Chicago

326 W

**MODERNIST**

Geometric Abstract Sculpture

circa 1970

aluminum, black wood composite base

overall height 23in (59cm); width 32in (81.5cm); base 7 1/2in (19cm) square

**\$1,000 - 1,500**

**To be sold without reserve**

**Provenance:**

Ziuta Gerstenzang Akston (1901-1994) and Joseph James Akston (1895-1983), Palm Beach, Florida

Thence by Descent

327

**PORTER BLANCHARD (1886-1973)**

Flatware Service

circa 1970

sterling, lucite, comprising six forks, six fish knives, eighteen cocktail forks and two serving forks; fish knife blades stamped 'STERLING PORTER BLANCHARD'; together with four similar cake and pie serving pieces (36)

**\$2,000 - 3,000**

**To be sold without reserve**

**Provenance:**

Ziuta Gerstenzang Akston (1901-1994) and Joseph James Akston (1895-1983), Palm Beach, Florida

Thence by Descent

328 W

**FLETCHER BENTON (BORN 1931)**

Synchronetic R-214-C

1971

acrylic, chromed metal

etched 'Fletcher Benton 1971 SYNCHRONETIC R-214-C'

height of sculpture 27 1/4in (69.5cm); width 23in (59cm); height of base 35in (89cm); width 16in (41cm); depth 11in (28cm)

**\$3,000 - 5,000**

**To be sold without reserve**

**Provenance:**

Ziuta Gerstenzang Akston (1901-1994) and Joseph James Akston (1895-1983), Palm Beach, Florida

Thence by Descent



327



328



329



330

329

**SVEN PALMQVIST (1906-1984)**

Ravenna Bowl

design introduced 1948

for Orrefors, glass, etched 'Orrefors Ravenna Nr 709 Sven Palmquist'  
*height 2 1/2in (6.5cm); width 6in (15cm); depth 5in (13cm)*

**\$1,500 - 2,000**

**To be sold without reserve**

**Provenance:**

Ziuta Gerstenzang Akston (1901-1994) and Joseph James Akston  
(1895-1983), Palm Beach, Florida  
Thence by Descent



331

330

**SEGUSO VETRI D'ARTE (1932-1973); ATTRIBUTED TO**

Rare Bowl

circa 1940

fasce bands in plum and pale green with gold inclusions, applied feet  
applied with gold inclusions

*height 4in (10cm); width 6 1/2in (16.5cm); depth 4 1/2in (11.5cm)*

**\$2,000 - 3,500**

**To be sold without reserve**

**Provenance:**

Ziuta Gerstenzang Akston (1901-1994) and Joseph James Akston  
(1895-1983), Palm Beach, Florida  
Thence by Descent



332

331

**GERALD BENNEY (1930-2008)**

Circular Box

1990

enamel, silver, stamped 'AGB GERALD BENNEY LONDON' and with  
British hallmarks

*height 1/2in (2.5cm); diameter 2 1/3in (6cm)*

**\$1,500 - 2,000**

332

**FARAONE**

Tea Pot

1994

sterling silver, stamped '3/9 Sets Sept 1994 FARAONE Milano'  
*height 6in (15cm); length 8in (20cm); depth 6in (15cm)*

**\$700 - 900**



333

333

**GUNNAR ANDERSEN (DIED 1950)**

Karen Pattern Flatware Service for Twelve

circa 1945

for Old Newbury Crafters, silver, six piece place setting with eight  
iced beverage spoons, a cake knife and a sugar spoon together with  
a Georg Jensen silver Cactus Pattern serving spoon, with original  
invoices and price list (83)

**\$2,500 - 4,500**

**Provenance:**

Georg Jensen, New York





(detail)

334

**ANDRE DUBREUIL (BORN 1951)**

Table Box

1980s

patinated bronze, copper, enamel

height 6in (15cm); width 16in (41cm); depth 12in (31cm)

**\$4,000 - 6,000**

**Provenance:**

Karl Kemp and Associates, Ltd., New York



335 W

**WILLIAM MORRIS (BORN 1957)**

Raven Jar

2009

patinated bronze, etched 'William Morris 2009 1/12'

25 x 16 x 13in (64 x 41 x 33cm)

**\$12,000 - 18,000**



336 W

**BOAZ VAADIA (BORN 1951)**

Gad with Dog

circa 1990

carved stone, pine, incised 'VB'

overall height 45in (115cm); width 21in (54cm); depth 15in (38cm)

**\$10,000 - 15,000**



337 W

**HANNEKE BEAUMONT (BORN 1947)**

Seated Figure on Steps

circa 1999

from the Melancholia series, patinated bronze, patinated wrought iron,  
incised 'HB'

height 97 1/4in (247cm); width 26in (66cm); depth 76 1/2in (194cm)

**\$20,000 - 30,000**



338 W

**WENDELL CASTLE (1932-2018)**

We All Have Reasons

1997

cherry and painted and carved wood, carved mark 'Castle 97'  
*height 38in (96.5cm); width 76in (193cm); depth 18in (45.7cm)*

**\$20,000 - 30,000**

**Exhibited:**

'Wendell Castle', Leo Kaplan Modern, New York, NY, November 6 -  
29, 1997

**Literature:**

Emily Evans Eerdmans, 'Wendell Castle: A Catalogue Raisonne 1958-  
2012', The Artist Foundation Book, 2014, p. 329





339 W

**WENDELL CASTLE (BORN 1932)**

Light Sculpture

2006

gilt fiberglass, impressed 'Castle 06'

height 84in (205cm); width 23in (58cm); depth 23 1/2in (60cm)

**\$7,000 - 10,000**





340 W

**JESUS BAUTISTA MORALES (1950-2015)**

Untitled

circa 1985

carved granite

*height 83.5in (212cm); width 22 1/4in (57cm); depth 14 1/2in (37cm)*

**\$4,000 - 6,000**

341 W

**MARK BRAZIER-JONES (BORN 1956)**

Shakti Mirror  
designed 2000  
painted plaster, beveled glass  
height 43 1/2in (109cm); width 23in (58.5cm); depth 2in (5cm)

**\$1,500 - 2,000**

**Provenance:**

Private Collection, Lugano, Switzerland

**Literature:**

Charlotte and Peter Fiell, 'Mark Brazier-Jones', Fiell Publishing, 2012, p.113



341

342 W

**GAETANO PESCE (BORN 1939)**

Up 5 Chair and Up 6 Ottoman  
designed 1969  
for B&B Italia, fabric, polyurethane  
height of chair 41in (104cm); width 44in (111.7cm); depth 50in (127cm); diameter of ottoman 23in (58.4cm)

**\$1,500 - 2,000**

343 W

**HERVÉ VAN DER STRAETEN (BORN 1965)**

Tabouret Capsule  
circa 2013  
lacquered aluminum  
height 13 3/4in (35cm); width 23 1/4in (59cm); 23 1/4in (59cm)

**\$1,800 - 2,500**

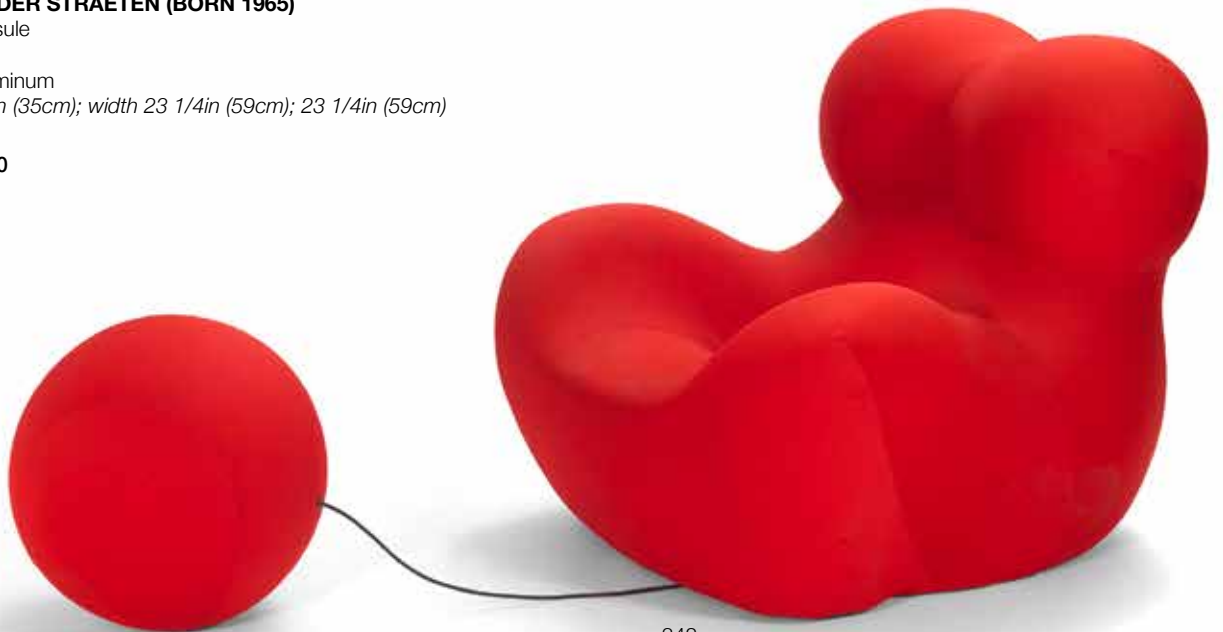

342



343

344

**PETER SHIRE (BORN 1947)**

Menorah

1988

painted steel, anodized aluminum, chromium, impressed 'SHIRE 1988  
EPPS'

height 9in (23cm); length 12in (30cm)

**\$1,200 - 1,800**

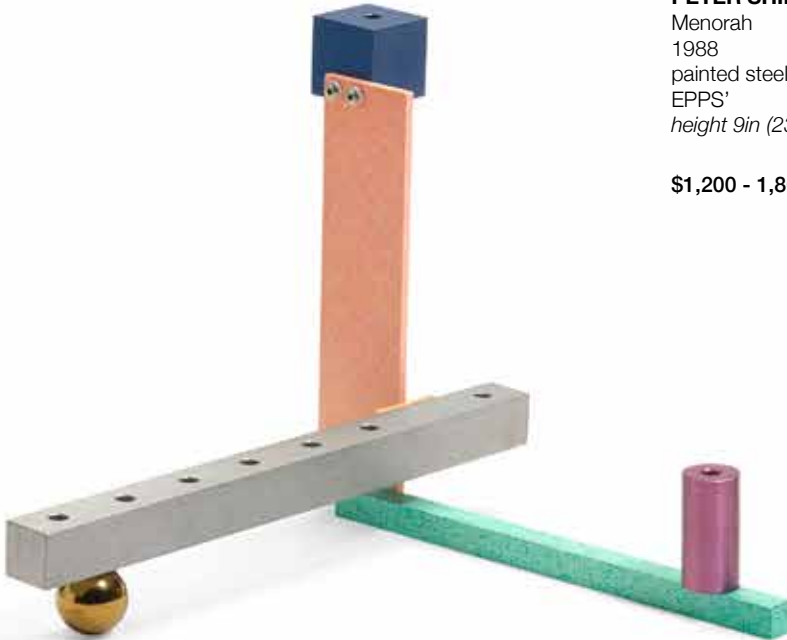

344

345

**PETER SHIRE (BORN 1947)**

Sake Pot

1981

glazed earthenware, signed and dated 'SHIRE X 1981' on the  
underside

height 4 3/4in (12cm); length 8 1/4in (21cm); depth 7/8in (2.3cm)

**\$1,000 - 1,500**



345

346

**ROSELINE DELISLE (1952-2003)**

Three Vessels with Covers

1989-1990

porcelain, each signed, dated or titled  
*height of largest 12in (30cm)*

**\$1,000 - 1,500**

347

**ELSA RADY (1943-2011)**

Bowl on Stand

1986

porcelain, patinated metal, inscribed on underside of base 'Elsa Rady  
1986'  
*height 5in (13cm); width 8in (20cm); depth 6 1/4in (16cm)*

**\$1,000 - 1,500**



346

347





348

348 W

**MICHAEL LUCERO (BORN 1953)**

Blue High

1990

polychromed and glazed earthenware, in five sections, signed 'Lucero'  
*height 108in (274cm)*

**\$9,000 - 12,000**

**Literature:**

20th Century Decorative Arts, Bonhams, New York, 9 December 9, 2009

349

**BEATRICE WOOD (1893-1998)**

Figural Vase

circa 1990

luster and turquoise glazed earthenware, painted in black 'BEATO'  
and 'BWTF 606'

*height 8 1/4in (21cm)*

**\$2,500 - 3,500**

350

**BEATRICE WOOD (1893-1998)**

Vase

luster glaze earthenware, painted in black 'BEATO'

*height 11in (27cm); diameter 7 1/2in (19cm)*

**\$1,200 - 1,800**



349



350

351

**ROBERT ARNESON (1930-1992)**

Dr. Cuss

1986

glazed stoneware, cement, incised 'ARNESON 1986'

height 16 1/2in (42cm); width 11in (28cm); depth 7in (18cm)

**\$30,000 - 50,000**

**Provenance:**

Private Collection, New England

**Literature:**

Fineberg, Jonathan. *A Troublesome Subject: The Art of Robert Arneson*. Berkeley: University of California Press, 2013, fig. p.180.



352 W

**KEN FERGUSON (1928-2004)**

Rabbit Handled Pouring Vessel  
circa 1995  
glazed stoneware, unsigned  
*height 15 1/4in (38.5cm)*

**\$2,000 - 3,000**



352

353 W

**RUDY AUTIO (1926-2007)**

Three Graces (Covered Vessel)  
1977  
glazed earthenware, signed and dated 'AUTIO 77'  
*height 28in (71.2cm); width 19in (48.3cm); depth  
16in (40.6cm)*

**\$3,000 - 5,000**

**Provenance:**

20th Century Decorative Arts and Design,  
Bonhams, Los Angeles, 27 October, 2014, lot 301  
Acquired directly from the above by the previous  
owner  
Thence by descent to the present owner  
Collection of Paul J.Coady



353

354

**RUTH DUCKWORTH (1919-2009)**

Untitled

1980

porcelain, glaze mark 'R80'

height 5in (12.5cm); width 17in (43cm); depth 16  
1/2in (42cm)

**\$10,000 - 15,000**

**Provenance:**

Private Collection, New England



354

355

**RUTH DUCKWORTH (1919-2009)**

Vase

1978

ceramic, signed in black 'R 78'

height 9 1/4in (23.3cm); diameter 9 1/4in (23.5cm)

**\$700 - 900**



355





356



357



358

356 W

**PETER CALLAS (BORN 1951)**

Tall Double Necked Vessel

1992

glazed stoneware, incised 'Callas 92'

height 22 1/2in (57cm)

**\$1,200 - 1,800**

357 W

**DON REITZ (1929-2014)**

Vessel

1993

salt glazed stoneware, incised 'Reitz 93'

height 36 1/4in (92cm)

**\$2,000 - 3,000**

358

**PAUL SOLDNER (1921-2011)**

Vase with Torn Rim

earthenware, unsigned

height 16 1/2in (42cm)

**\$1,000 - 1,500**



359 W

**PETER VOULKOS**

Untitled (Plate)

1987

gas-fired wheel-thrown stoneware with push-throughs and clear glaze, painted 'Voukos' and '87' on underside

diameter 20in (51cm)

**\$6,000 - 8,000**

The offered lot is listed under 'CR949.20-G' in the Voukos & Co. catalogue project quest database

**Provenance:**

Private Collection, Northern California (acquired directly from the artist)

Made in California, Bonhams, Los Angeles, 3 May 2010

Collection of Paul J. Coady



359

360 W

**PETER VOULKOS**

Untitled (Plate)

1983

wood fired wheel-thrown and manipulated stoneware with glaze, painted 'Voukos 83' on underside

diameter 23in (59cm)

**\$6,000 - 8,000**

The offered lot is listed under 'CR945-W' in the Voukos & Co. catalogue project quest database

**Provenance:**

Made in California, Bonhams, Los Angeles, 2 April 2013

Collection of Paul J. Coady

**Exhibited:**

San Francisco, Braunstein Gallery, *Voukos*, March 3-31, 1984, no. 3; Oakland, The Oakland Museum, *The Art of Peter Voukos*, July 22-November 12, 1995, illus. p. 133, pl. 57. Traveled to Newport Harbor Art Museum, Newport Beach; American Craft Museum, New York.



360

361

**BERNARD LEACH (1887-1979)**

Cut Sided Bowl

circa 1965

stoneware, stamped with St. Ives seal and 'BL' monogram

height 4 3/4in (12cm); diameter 8 1/4in (21cm)

**\$1,200 - 1,800**



361

362

**DAVID LEACH (1911-2005)**

Group of Three Vessels

circa 1980

glazed stoneware and porcelain; comprising a shouldered vase, ovoid vase and a fluted tea bowl, each impressed with 'DL' seal, the largest also impressed 'TL'

heights 3 1/8in (8cm); 5 3/4in (14.6cm); 11 3/4in (30cm)

**\$1,500 - 2,000**



362

363

**ROBERT TURNER (1913-2005)**

Ashanti

circa 1991-92

glazed stoneware, sandblasted, incised 'Turner'  
height 15 1/2in (39cm); diameter 11in (28cm)

**\$6,000 - 8,000**

**Provenance:**

Helen Drutt Gallery, Philadelphia, Pennsylvania  
Acquired from the above, June 5, 2005

364

**ROBERT TURNER (1913-2005)**

Akan

circa 1985

glazed and sandblasted stoneware, incised mark 'Turner'  
height 12in (30.5cm); diameter 9in (23cm)

**\$4,000 - 6,000**

**Provenance:**

Helen Drutt Gallery, Philadelphia, Pennsylvania  
Acquired from the above, 1992

363



364





365

365

**MARGUERITE WILDENHAIN (1896-1985)**

Two Bowls and a Pitcher  
1956-1970

glazed stoneware, each incised 'Pond Farm' and with maker's marks on underside

height of largest 9 1/2in (24.5cm); width 5 3/4in (14.5cm); depth 5 3/4in (14.5cm)

**\$2,000 - 3,000**

Collection of Olive Thompson Cowell (gift from the artist)  
Acquired from the above by the present owner

366

**MARGUERITE WILDENHAIN (1896-1985)**

Group of Six Table Objects  
circa 1950

glazed stoneware, two bowls and two pitchers incised 'Pond Farm', vase incised 'Wildenhain' and red bowl incised with artist's monogram

height of largest 4in (10cm)

**\$1,000 - 1,500**

Collection of Olive Thompson Cowell (gift from the artist)  
Acquired from the above by the present owner



366





367

367

**MARGUERITE WILDENHAIN (1896-1985)**

Group of Five Table Objects

circa 1950

glazed stoneware, each incised 'Pond Farm' or with maker's marks

height of largest 5 1/2in (14.2cm)

**\$1,500 - 2,000**

Collection of Olive Thompson Cowell (gift from the artist)

Acquired from the above by the present owner

368

**MARGUERITE WILDENHAIN (1896-1985)**

Footed Vase

circa 1950

glazed stoneware, incised 'Pond Farm'

height 12 1/2in (31cm); width 5 1/2in (14cm); depth 5 3/4in (14.5cm)

**\$1,500 - 2,000**

Collection of Olive Thompson Cowell (gift from the artist)

Acquired from the above by the present owner



368



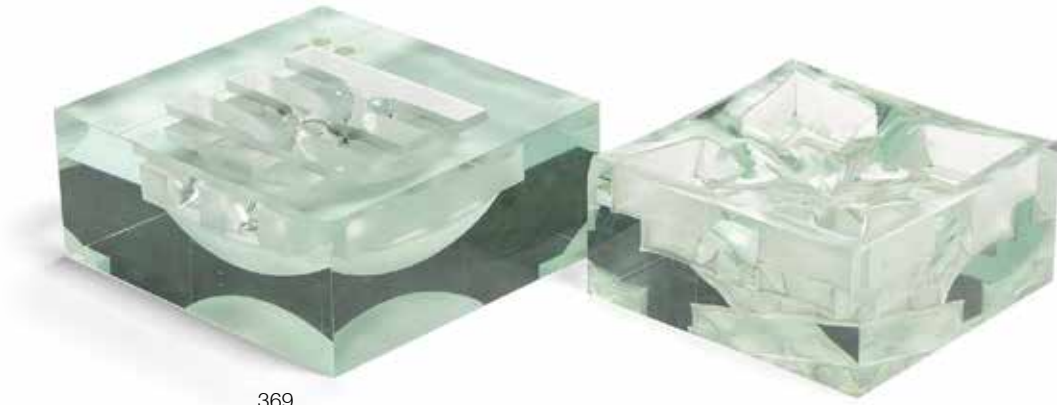

369

369

**STEVEN WEINBERG (BORN 1954)**

Two Puzzles

1979

cast and cut glass, signed 'WEINBERG 79'

height 3 1/4in (8.4cm); width 7 1/2in (19cm); depth 8in (20cm); height 3in (8cm); width 6 1/2in (17cm); depth 6 1/2in (17cm)

**\$1,500 - 2,000**

370

**STEVEN WEINBERG (BORN 1954)**

Cube No. 780206

cast glass, signed 'WEINBERG 780206'

height 5 1/4in (13.4cm); width 5 3/8in (13.7cm); depth 5 3/8in (13.7cm)

**\$1,200 - 1,800**

371

**STEVEN WEINBERG (BORN 1954)**

Puzzle No. 810601

cast and cut glass, signed 'WEINBERG 810601'

height 8 3/4in (22.4cm); width 8 3/4in (22.4cm); depth 3 3/4in (9.5cm)

**\$1,500 - 2,000**

370

371



372 W

**JOHN LEWIS (BORN 1942)**

Glacier with Yellow Gold

2007

cast glass, gilding, inscribed 'Lewis 07-42'

height 26in (66cm); width 21in (53.4cm); depth 10in (25.4cm)

**\$4,000 - 6,000**

373 W

**JOHN LEWIS (BORN 1942)**

Glacier Winged Vessel

2011

glass, gilding, etched signature 'Lewis 11-01'

height 6in (15cm); width 27in (69cm); depth 11 1/2in (29cm)

**\$2,500 - 3,500**

372



373



374



375



376

374

**MICHAEL PAVLIK (BORN 1941)**

Two Part Sculpture on Stand

1981

cut, polished and laminated glass, both parts inscribed 'Michael Pavlik 81' in script and numbered '1605'

height 8in (22cm); approximate width 12 1/2in (31.8cm); depth 12in (30.5cm)

**\$1,000 - 1,500**

375

**MAZZEGA**

Eliel Saarinen Building Model

glass, etched 'MARINA CITTA VENEZIA/ELIEL SAARINEN/L.V.R. Di MAZZEGA MURANO'

height 13in (33cm); diameter of base 10in (25cm)

**\$1,500 - 2,000**

376 W

**LUCIO BUBACCO (BORN 1957)**

Angelic Hellish Collaboration

1998

blown glass, etched 'Lucio Bubacco 98'

height 21 1/2in (54cm); diameter 15in (38cm)

**\$2,000 - 4,000**

377 W

**DANNY PERKINS (BORN 1955)**

Sculpture

1995

blown and painted glass, inscribed 'DANNY PERKINS 1995 UND 612  
GLASS VIOLA'

height 39 1/2in (101cm); width 10in (26cm); depth 9 1/4in (23.5cm)

\$2,500 - 3,500

378 W

**DANNY PERKINS (BORN 1955)**

Sculpture

circa 1995

blown and painted glass, unsigned

height 65in (165cm); width 14in (36cm); depth 10in (26cm)

\$4,000 - 6,000



377



378



379

**DALE CHIHULY (BORN 1941)**

Five Piece Basket Set

1987

blown glass, etched 'Chihuly 1987'

largest component 15 x 12in (38 x 30.5cm)

**\$5,000 - 7,000**

**Provenance:**

Habatat Galleries, Michigan

Collection of Barbara and Milford Nemer, Michigan

380

**DALE CHIHULY (BORN 1941)**

Vermilion and Orange Persian Set with Blue Lip Wraps

1988

blown glass, signed 'Chihuly 88', together with a copy of the original receipt from Betsy Rosenfeld Gallery, Inc.

9in x 25in x 17in (23cm x 63.5cm x 43.3cm)

**\$7,000 - 10,000**

**Provenance:**

Betsy Rosenfeld Gallery, Inc.

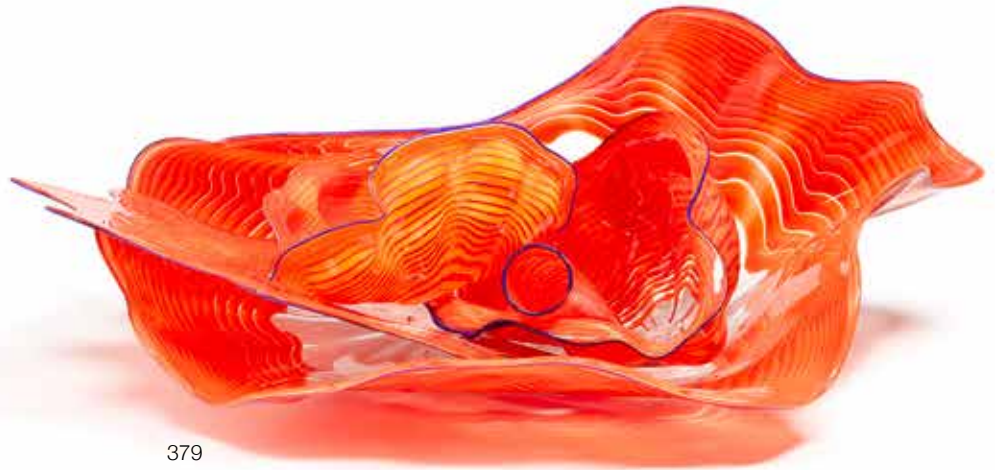

379

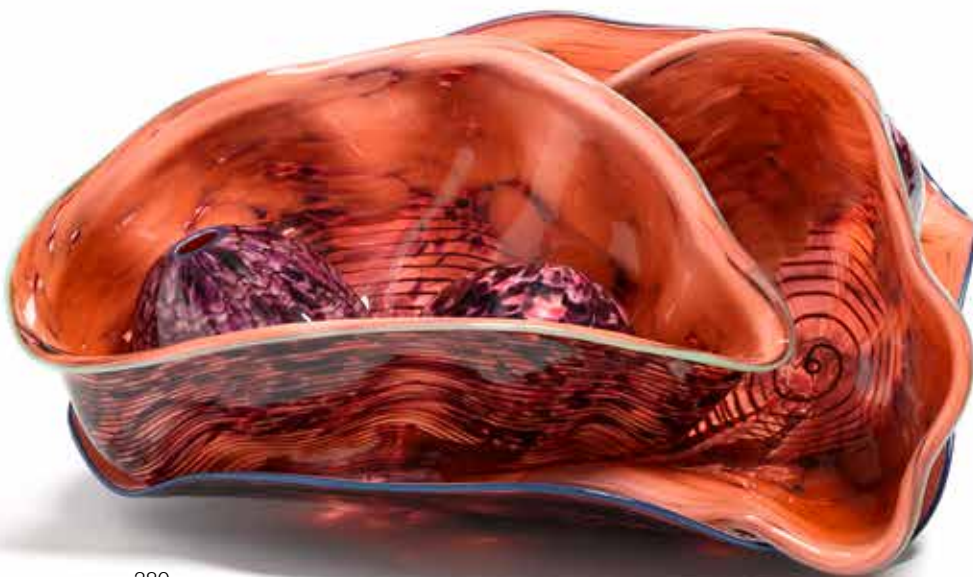

380



381

**DALE CHIHULY (BORN 1941)**

Soft Cylinder

1990

blown glass, engraved 'Chihuly 90'

height 11in (27.9cm); width 13 1/2in (34.2cm); depth 9in (22.86cm)

**\$8,000 - 12,000**

**Provenance:**

Private Collection, Southern California



382

**MARY ANN (TOOTS) ZYNSKY (BORN 1951)**

Gratticcio Serena

2001

fused and slumped glass threads, monogrammed 'Z' on underside

8 1/2 x 17 1/4 x 9 1/4in (22 x 44 x 23.5cm)

\$8,000 - 12,000



383

**MARVIN LIPOFSKY (1938-2016)**

Frauenau Group 2

2000

blown glass, lightly etched signature and further inscription on base

16 1/2 X 18 X 15 1/2in (42 x 46 x 39cm)

\$3,000 - 5,000





384 W

**BARRY SAUTNER (BORN 1952)**

Chariots of Fire

1995

frosted and colorless glass, carved marble, etched 'Barry Sautner 1995'

12 x 15 x 6in (30 x 38 x 15cm)

\$1,500 - 2,500

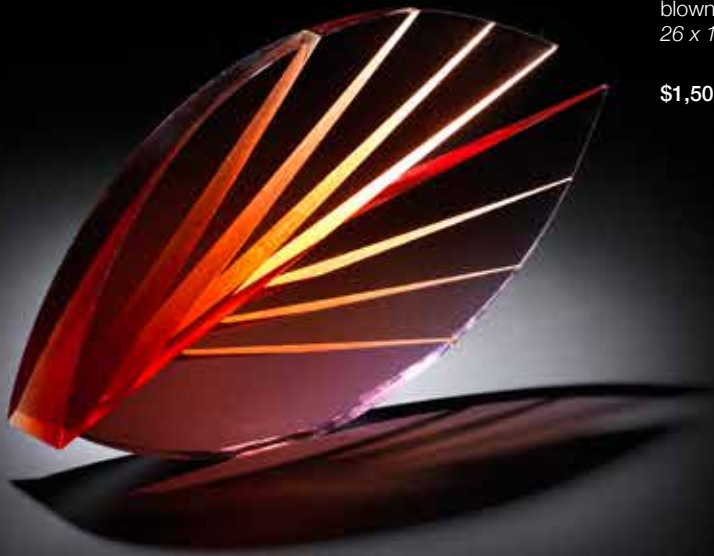

385 W

**PAVEL HLAVA (1924-2003)**

Red Leaf

1994

blown glass, gold leaf, signed, dated and inscribed along edge

26 x 13 x 3in (66 x 33 x 8cm)

\$1,500 - 2,500

386

**WILLIAM MORRIS (BORN 1957)**

Medicine Jar with Cover: Cricket

2005

blown and lamp worked glass, braided fiber, enameled steel stand

height 17 1/2in (44.5cm)

\$40,000 - 60,000





387

**LAURA DE SANTILLANA (BORN 1955)**

Untitled Flag

Circa 2004

engraved mark 'LAURA DE SANTILLANA 2004'

*height 14 1/4in (36.2cm); width 12 1/4in (31.1cm); depth 2in (5cm)*

**\$6,000 - 8,000**

**Provenance:**

Private Collection, Chicago



388 W

**STANISLAV LIBENSKÝ AND JAROSLAVA BRYCHTOVÁ**

Rhomboid Head

1991

cast glass, signed

19 3/8 x 22 1/8 x 9 1/4 in (49.2 x 56.2 x 23.5cm)

**\$18,000 - 25,000**

**Provenance:**

Habatat Galleries, Royal Oak, Michigan

Private Collection, Chicago



## OFFSITE SOLD PROPERTY STORAGE INFORMATION

Please note that all lots listed at the beginning of our printed catalog, if not removed immediately after the sale, will be transferred to a nearby storage facility. For the convenience of the successful bidder of one or more of these lots, all purchased lots will be transferred to our offsite storage together. Please read the Conditions of Sale regarding the removal of sold lots.

Bonhams' storage and logistics partner is Box, Pack, & Ship, llc, a well-known organization that specializes in crating, packaging and shipping.

Our storage and logistics partnership provides several beneficial services. The first being 5 days of free storage.

- During this auction, clients will be expected to pick up all property from Bonhams by 5pm on Friday, April 26.
- All items listed at the beginning of our printed catalog, along with all other items purchased, if not removed immediately after the sale, will be transferred to Box, Pack, & Ship, llc warehouse. With an appointment made 24 hours in advance, clients can pick up their property at 3800 S. Main Street Los Angeles, CA 90037.
- Box, Pack, & Ship, llc will charge an uplift fee to transport your items to their warehouse. Small items that can be handled easily by one person will be charged \$50. Larger items that can still be handled by one person will be charged \$85. Large items that require two people to handle will be charged \$100. Charges will be payable directly to Box, Pack, & Ship, llc. Should you choose to have Box, Pack, & Ship, llc ship or deliver your property, this uplift fee will be waived.
- Clients will have 5 days of free storage to retrieve their property or make arrangements with Box, Pack, & Ship, llc to pack and ship their property. Storage fees will begin to accrue on the 6th day of storage.
- Retrieval from the offsite warehouse is by appointment only. Clients must call 24 hours in advance. Clients can utilize the delivery services offered by Box, Pack, & Ship, llc or clients may make their own arrangements. Please call +1 (800) 674 4705.
- Box, Pack, & Ship, llc is available to ship internationally. They offer importing and exporting services. Clients can select either airfreight or ocean cargo delivery options, which range from door-to-port, door-to-airport with door-to-door service also available. Clients can ship one item, co-load or container load at a discounted rate through Box, Pack, & Ship, llc. Please call +1 (800) 674 4705 for more information.
- All purchases not designated for offsite storage will remain onsite at Bonhams for a period of 21 days beginning the date of the auction. During this 21 day period, clients may remove such property themselves, make arrangements with the Bonhams packaging and shipping department or provide their own shipper for removal of all property. If a client does not retrieve his/her property or finalize shipping arrangements within 21 days, the purchases will be removed to the offsite storage facility of Box, Pack, & Ship, llc. Again, uplift charges for packing and transport from our gallery to Box, Pack, & Ship, llc will be charged by Box, Pack, & Ship, llc.
- Payment of the hammer price, premium and any applicable sales taxes must be made directly to Bonhams prior to the release of property. Any removal, storage or other fees due to Box, Pack, & Ship, llc should be made directly to Box, Pack, & Ship, llc.
- Change of shipping address must be authorized by Bonhams Revenue Manager, Martin Romero, before Box, Pack, & Ship, llc will be permitted to re-route your purchases.

## LOTS TO BE REMOVED TO STORAGE:

20	161	238	294
21	162	239	295
22	163	240	296
24	165	241	297
25	166	242	298
26	167	243	299
38	170	244	300
39	171	245	301
41	172	246	302
42	173	247	303
44	174	248	304
53	175	250	305
54	176	251	306
56	177	252	307
59	178	253	308
60	179	254	309
71	180	255	310
72	181	256	313
73	182	257	314
74	183	258	315
76	184	260	316
78	185	261	317
81	186	262	318
82	188	263	319
87	189	264	326
88	191	265	328
89	192	266	335
90	193	267	336
92	194	268	337
93	198	269	338
94	199	270	339
95	200	271	340
96	201	272	341
97	202	273	342
98	203	274	343
99	204	275	348
122	205	279	352
146	206	280	353
148	207	281	356
149	209	282	357
150	218	283	359
151	219	284	360
152	226	285	372
153	227	286	373
154	228	287	376
155	229	288	377
156	233	289	378
157	234	290	384
158	235	291	385
159	236	292	388
160	237	293	

## CONDITIONS OF SALE

The following Conditions of Sale, as amended by any published or posted notices or verbal announcements during the sale, constitute the entire terms and conditions on which property listed in the catalog shall be offered for sale or sold by Bonhams & Butterfields Auctioneers Corp. and any consignor of such property for whom we act as agent. If live online bidding is available for the subject auction, additional terms and conditions of sale relating to online bidding will apply; see [www.bonhams.com/WebTerms](http://www.bonhams.com/WebTerms) for the supplemental terms. As used herein, "Bonhams," "we" and "us" refer to Bonhams & Butterfields Auctioneers Corp.

1. As used herein, the term "bid price" means the price at which a lot is successfully knocked down to the purchaser. The term "purchase price" means the aggregate of (a) the bid price, (b) a PREMIUM retained by us and payable by the purchaser EQUAL TO 27.5% OF THE FIRST \$3,000 OF THE BID PRICE, 25% OF THE AMOUNT OF THE BID PRICE ABOVE \$3,000 UP TO AND INCLUDING \$400,000, 20% OF THE AMOUNT OF THE BID PRICE ABOVE \$400,000 UP TO AND INCLUDING \$4,000,000, AND 13.9% OF THE AMOUNT OF THE BID PRICE OVER \$4,000,000, and (c) unless the purchaser is exempt by law from the payment thereof, any Alabama, Arizona, California, Colorado, Connecticut, Florida, Georgia, Hawaii, Idaho, Illinois, Iowa, Indiana, Kentucky, Louisiana, Maine, Massachusetts, Michigan, Minnesota, Nevada, New Jersey, New York, North Carolina, Ohio, Pennsylvania, Rhode Island, Texas, Utah, Virginia, Washington, D.C., Washington state, Wisconsin, Wyoming or other state or local sales tax (or compensating use tax) and other applicable taxes. With regard to New York sales tax, please refer to the "Sales and Use Tax" section of these Conditions of Sale.

2. On the fall of the auctioneer's hammer, the highest bidder shall have purchased the offered lot in accordance and subject to compliance with all of the conditions set forth herein and (a) assumes full risk and responsibility therefor, (b) if requested will sign a confirmation of purchase, and (c) will pay the purchase price in full or such part as we may require for all lots purchased. No lot may be transferred. Any person placing a bid as agent on behalf of another (whether or not such person has disclosed that fact or the identity of the principal) may be jointly and severally liable with the principal under any contract resulting from the acceptance of a bid.

Unless otherwise agreed, payment in good funds is due and payable within five (5) business days following the auction sale. Whenever the purchaser pays only a part of the total purchase price for one or more lots purchased, we may apply such payments, in our sole discretion, to the lot or lots we choose. Payment will not be deemed made in full until we have collected good funds for all amounts due.

Payment for purchases may be made in or by (a) cash, (b) cashier's check or money order, (c) personal check with approved credit drawn on a U.S. bank, (d) wire transfer or other immediate bank transfer, or (e) Visa, MasterCard, American Express or Discover credit, charge or debit card. A processing fee will be assessed on any returned checks. Please note that the amount of cash notes and cash equivalents that can be accepted from a given purchaser may be limited.

To the fullest extent permitted by applicable law: The purchaser grants us a security interest in the property, and we may retain as collateral security for the purchaser's obligations to us, any property and all monies held or received by us for the account of the purchaser, in our possession. We also retain all rights of a secured party under the California Commercial Code. If the foregoing conditions or any other applicable conditions herein are not complied with, in addition to all other remedies available to us and the consignor by law, we may at our election: (a) hold the purchaser liable for the full purchase price and any

late charges, collection costs, attorneys' fees and costs, expenses and incidental damages incurred by us or the consignor arising out of the purchaser's breach; (b) cancel the sale, retaining as liquidated damages all payments made by the purchaser; and/or (c) cancel the sale and/or resell the purchased property, at public auction and/or by private sale, and in such event the purchaser shall be liable for the payment of all consequential damages, including any deficiencies or monetary losses, and all costs and expenses of such sale or sales, our commissions at our standard rates, all other charges due hereunder, all late charges, collection costs, attorneys' fees and costs, expenses and incidental damages. In addition, where two or more amounts are owed in respect of different transactions by the purchaser to us, to Bonhams 1793 Limited and/or to any of our other affiliates, subsidiaries or parent companies worldwide within the Bonhams Group, we reserve the right to apply any monies paid in respect of a transaction to discharge any amount owed by the purchaser. If all fees, commissions, premiums, bid prices and other sums due to us from the purchaser are not paid promptly as provided in these Conditions of Sale, we reserve the right to impose a finance charge equal to 1.5% per month (or, if lower, the maximum nonusurious rate of interest permitted by applicable law), on all amounts due to us beginning on the 31st day following the sale until payment is received, in addition to other remedies available to us by law.

3. We reserve the right to withdraw any property and to divide and combine lots at any time before such property's auction. Unless otherwise announced by the auctioneer at the time of sale, all bids are per lot as numbered in the catalog and no lots shall be divided or combined for sale.

4. We reserve the right to reject a bid from any bidder, to split any bidding increment, and to advance the bidding in any manner the auctioneer may decide. In the event of any dispute between bidders, or in the event the auctioneer doubts the validity of any bid, the auctioneer shall have sole and final discretion either to determine the successful bidder or to re-offer and resell the article in dispute. If any dispute arises after the sale, our sales records shall be conclusive in all respects.

5. If we are prevented by fire, theft or any other reason whatsoever from delivering any property to the purchaser or a sale otherwise cannot be completed, our liability shall be limited to the sum actually paid therefor by the purchaser and shall in no event include any compensatory, incidental or consequential damages.

6. If a lot is offered subject to a reserve, we may implement such reserve by bidding on behalf of the consignor, whether by opening bidding or continuing bidding in response to other bidders until reaching the reserve. If we have an interest in an offered lot and the proceeds therefrom other than our commissions, we may bid therefor to protect such interest. **CONSIGNORS ARE NOT ALLOWED TO BID ON THEIR OWN ITEMS.**

7. All statements contained in the catalog or in any bill of sale, condition report, invoice or elsewhere as to authorship, period, culture, source, origin, measurement, quality, rarity, provenance, importance, exhibition and literature of historical relevance, or physical condition **ARE QUALIFIED STATEMENTS OF OPINION AND NOT REPRESENTATIONS OR WARRANTIES.** No employee or agent of Bonhams is authorized to make on our behalf or on that of the consignor any representation or warranty, oral or written, with respect to any property.

8. All purchased property shall be removed from the premises at which the sale is conducted by the date(s) and time(s) set forth in the "Buyer's Guide" portion of this catalog. Property designated with a "W" and associated purchased lots, if not removed promptly following sale, will be transferred to an offsite warehouse at the purchaser's

risk and expense, as set forth in more detail in the "Buyer's Guide." Purchased property that is permitted to remain onsite at Bonhams' facility should be removed at the purchaser's expense not later than 5:00 p.m. Pacific Time five (5) business days following the date of the sale. If not so removed, a storage fee of \$5.00 per lot per day will be payable to us by the purchaser beginning at the close of the 21st day following the sale, and we may thereafter transfer such property to an offsite warehouse at the purchaser's risk and expense. Accounts must be settled in full before property will be released. Packing and handling of purchased lots are the responsibility of the purchaser. Bonhams can provide packing and shipping services for certain items as noted in the "Buyer's Guide" section of the catalog.

9. The copyright in the text of the catalog and the photographs, digital images and illustrations of lots in the catalog belong to Bonhams or its licensors. You will not reproduce or permit anyone else to reproduce such text, photographs, digital images or illustrations without our prior written consent.

10. These Conditions of Sale shall bind the successors and assigns of all bidders and purchasers and inure to the benefit of our successors and assigns. No waiver, amendment or modification of the terms hereof (other than posted notices or oral announcements during the sale) shall bind us unless specifically stated in writing and signed by us. If any part of these Conditions of Sale is for any reason invalid or unenforceable, the rest shall remain valid and enforceable.

11. These Conditions of Sale and the purchaser's and our respective rights and obligations hereunder are governed by the laws of the State of California. By bidding at an auction, each purchaser and bidder agrees to be bound by these Conditions of Sale. Any dispute, controversy or claim arising out of or relating to this agreement, or the breach, termination or validity thereof, brought by or against Bonhams (but not including claims brought against the consignor by the purchaser of lots consigned hereunder) shall be resolved by the procedures set forth below.

### MEDIATION AND ARBITRATION PROCEDURES

(a) Within 30 days of written notice that there is a dispute, the parties or their authorized and empowered representatives shall meet by telephone and/or in person to mediate their differences. If the parties agree, a mutually acceptable mediator shall be selected and the parties will equally share such mediator's fees. The mediator shall be a retired judge or an attorney familiar with commercial law and trained in or qualified by experience in handling mediations. Any communications made during the mediation process shall not be admissible in any subsequent arbitration, mediation or judicial proceeding. All proceedings and any resolutions thereof shall be confidential, and the terms governing arbitration set forth in paragraph (c) below shall govern.

(b) If mediation does not resolve all disputes between the parties, or in any event no longer than 60 days after receipt of the written notice of dispute referred to above, the parties shall submit the dispute for binding arbitration before a single neutral arbitrator. Such arbitrator shall be a retired judge or an attorney familiar with commercial law and trained in or qualified by experience in handling arbitrations. Such arbitrator shall make all appropriate disclosures required by law. The arbitrator shall be drawn from a panel of a national arbitration service agreed to by the parties, and shall be selected as follows: (i) If the national arbitration service has specific rules or procedures, those rules or procedures shall be followed; (ii) If the national arbitration service does not have rules or procedures for the selection of an arbitrator, the arbitrator shall be an individual jointly agreed to by the parties. If the parties cannot agree on a national arbitration service, the arbitration shall be

## CONDITIONS OF SALE - CONTINUED

conducted by the American Arbitration Association, and the arbitrator shall be selected in accordance with the Rules of the American Arbitration Association. The arbitrator's award shall be in writing and shall set forth findings of fact and legal conclusions.

(c) Unless otherwise agreed to by the parties or provided by the published rules of the national arbitration service:

(i) the arbitration shall occur within 60 days following the selection of the arbitrator;

(ii) the arbitration shall be conducted in the designated location, as follows: (A) in any case in which the subject auction by Bonhams took place or was scheduled to take place in the State of New York or Connecticut or the Commonwealth of Massachusetts, the arbitration shall take place in New York City, New York; (B) in all other cases, the arbitration shall take place in the city of San Francisco, California; and

(iii) discovery and the procedure for the arbitration shall be as follows:

(A) All arbitration proceedings shall be confidential;

(B) The parties shall submit written briefs to the arbitrator no later than 15 days before the arbitration commences;

(C) Discovery, if any, shall be limited as follows: (I) Requests for no more than 10 categories of documents, to be provided to the requesting party within 14 days of written request therefor; (II) No more than two (2) depositions per party, provided however, the deposition(s) are to be completed within one (1) day; (III) Compliance with the above shall be enforced by the arbitrator in accordance with California law;

(D) Each party shall have no longer than eight (8) hours to present its position. The entire hearing before the arbitrator shall not take longer than three (3) consecutive days;

(E) The award shall be made in writing no more than 30 days following the end of the proceeding. Judgment upon the award rendered by the arbitrator may be entered by any court having jurisdiction thereof.

To the fullest extent permitted by law, and except as required by applicable arbitration rules, each party shall bear its own attorneys' fees and costs in connection with the proceedings and shall share equally the fees and expenses of the arbitrator.

### LIMITED RIGHT OF RESCISSION

If within one (1) year from the date of sale, the original purchaser (a) gives written notice to us alleging that the identification of Authorship (as defined below) of such lot as set forth in the **BOLD TYPE** heading of the catalog description of such lot (as amended by any saleroom notices or verbal announcements during the sale) is not substantially correct based on a fair reading of the catalog (including the terms of any glossary contained therein), and (b) within 10 days after such notice returns the lot to us in the same condition as at the time of sale, and (c) establishes the allegation in the notice to our satisfaction (including by providing one or more written opinions by recognized experts in the field, as we may reasonably require), then the sale of such lot will be rescinded and, unless we have already paid to the consignor monies owed him in connection with the sale, the original purchase price will be refunded.

If, prior to receiving such notice from the original purchaser alleging such defect, we have paid the consignor monies owed him in connection with the sale, we shall pay the original purchaser the amount of our commissions, any other sale proceeds to which we are entitled and applicable taxes received from the purchaser on the sale and make demand on the consignor to pay the balance of the original purchase price to the original purchaser. Should the consignor fail to pay such amount promptly, we may disclose the identity of the consignor and assign to the original purchaser our rights against the consignor with respect to the lot the sale of which is sought to be rescinded. Upon such disclosure and assignment, any liability of Bonhams as consignor's agent with respect to said lot shall automatically terminate.

The foregoing limited right of rescission is available to the original purchaser only and may not be assigned to or relied upon by any subsequent transferee of the property sold. The purchaser hereby accepts the benefit of the consignor's warranty of title and other representations and warranties made by the consignor for the purchaser's benefit. Nothing in this section shall be construed as an admission by us of any representation of fact, express or implied, obligation or responsibility with respect to any lot. **THE PURCHASER'S SOLE AND EXCLUSIVE**

**REMEDY AGAINST BONHAMS FOR ANY REASON WHATSOEVER IS THE LIMITED RIGHT OF RESCISSION DESCRIBED IN THIS SECTION.**

"Authorship" means only the identity of the creator, the period, culture and source or origin of the lot, as the case may be, as set forth in the **BOLD TYPE** heading of the print catalog entry. The right of rescission does not extend to: (a) works of art executed before 1870 (unless these works are determined to be counterfeits created since 1870), as this is a matter of current scholarly opinion which can change; (b) titles, descriptions, or other identification of offered lots, which information normally appears in lower case type below the **BOLD TYPE** heading identifying the Authorship; (c) Authorship of any lot where it was specifically mentioned that there exists a conflict of specialist or scholarly opinion regarding the Authorship of the lot at the time of sale; (d) Authorship of any lot which as of the date of sale was in accordance with the then generally-accepted opinion of scholars and specialists regarding the same; or (e) the identification of periods or dates of creation in catalog descriptions which may be proven inaccurate by means of scientific processes that are not generally accepted for use until after publication of the catalog in which the property is offered or that were unreasonably expensive or impractical to use at the time of such publication.

### LIMITATION OF LIABILITY

EXCEPT AS EXPRESSLY PROVIDED ABOVE, ALL PROPERTY IS SOLD "AS IS." NEITHER BONHAMS NOR THE CONSIGNOR MAKES ANY REPRESENTATION OR WARRANTY, EXPRESS OR IMPLIED, AS TO THE MERCHANTABILITY, FITNESS OR CONDITION OF THE PROPERTY OR AS TO THE CORRECTNESS OF DESCRIPTION, GENUINENESS, ATTRIBUTION, PROVENANCE OR PERIOD OF THE PROPERTY OR AS TO WHETHER THE PURCHASER ACQUIRES ANY COPYRIGHTS OR OTHER INTELLECTUAL PROPERTY RIGHTS IN LOTS SOLD OR AS TO WHETHER A WORK OF ART IS SUBJECT TO THE ARTIST'S MORAL RIGHTS OR OTHER RESIDUAL RIGHTS OF THE ARTIST. THE PURCHASER EXPRESSLY ACKNOWLEDGES AND AGREES THAT IN NO EVENT SHALL BONHAMS BE LIABLE FOR ANY DAMAGES INCLUDING, WITHOUT LIMITATION, ANY COMPENSATORY, INCIDENTAL OR CONSEQUENTIAL DAMAGES.

## SELLER'S GUIDE

### SELLING AT AUCTION

Bonhams can help you every step of the way when you are ready to sell art, antiques and collectible items at auction. Our regional offices and representatives throughout the US are available to service all of your needs. Should you have any further questions, please visit our website at [www.bonhams.com/us](http://www.bonhams.com/us) for more information or call our Client Services Department at +1 (323) 850 7500.

### AUCTION ESTIMATES

The first step in the auction process is to determine the auction value of your property. Bonhams' world-renowned specialists will evaluate your special items at no charge and in complete confidence. You can obtain an auction estimate in many ways:

- Attend one of our Auction Evaluation Events held regularly at our galleries and in other major metropolitan areas. The updated schedule for Bonhams Auction Evaluation Events is available at [www.bonhams.com/us](http://www.bonhams.com/us).
- Call our Client Services Department to schedule a private appointment at one of our galleries. If you have a large collection, our specialists can travel, by appointment, to evaluate your property on site.
- Send clear photographs to us of each individual item, including item dimensions and other pertinent information with each picture. Photos should be sent to Bonhams' address in envelopes marked

as "photo auction estimate". Alternatively, you can submit your request using our online form at [www.bonhams.com/us](http://www.bonhams.com/us). Digital images may be attached to the form. Please limit your images to no more than five (5) per item.

### CONSIGNING YOUR PROPERTY

After you receive an estimate, you may consign your property to us for sale in the next appropriate auction. Our staff assists you throughout the process, arranging transportation of your items to our galleries (at the consignor's expense), providing a detailed inventory of your consignment, and reporting the prices realized for each lot. We provide secure storage for your property in our warehouses and all items are insured throughout the auction process. You will receive payment for your property approximately 35 days after completion of sale.

Sales commissions vary with the potential auction value of the property and the particular auction in which the property is offered. Please call us for commission rates.

### PROFESSIONAL APPRAISAL SERVICES

Bonhams' specialists conduct insurance and fair market value appraisals for private collectors, corporations, museums, fiduciaries and government entities on a daily basis. Insurance appraisals, used for insurance purposes, reflect the cost of replacing property in today's retail market. Fair market value appraisals are used for estate,

tax and family division purposes and reflect prices paid by a willing buyer to a willing seller.

When we conduct a private appraisal, our specialists will prepare a thorough inventory listing of all your appraised property by category. Valuations, complete descriptions and locations of items are included in the documentation.

Appraisal fees vary according to the nature of the collection, the amount of work involved, the travel distance, and whether the property is subsequently consigned for auction.

Our appraisers are available to help you anywhere and at any time. Please call our Client Services Department to schedule an appraisal.

### ESTATE SERVICES

Since 1865, Bonhams has been serving the needs of fiduciaries – lawyers, trust officers, accountants and executors – in the disposition of large and small estates. Our services are specially designed to aid in the efficient appraisal and disposition of fine art, antiques, jewelry, and collectibles. We offer a full range of estate services, ranging from flexible financial terms to tailored accounting for heirs and their agents to world-class marketing and sales support.

For more information or to obtain a detailed Trust and Estates package, please visit our website at [www.bonhams.com/us](http://www.bonhams.com/us) or contact our Client Services Department.



# BUYER'S GUIDE

## BIDDING & BUYING AT AUCTION

Whether you are an experienced bidder or an enthusiastic novice, auctions provide a stimulating atmosphere unlike any other. Bonhams previews and sales are free and open to the public. As you will find in these directions, bidding and buying at auction is easy and exciting. Should you have any further questions, please visit our website at [www.bonhams.com](http://www.bonhams.com) or call our Client Services Department at +1 (323) 850 7500.

### Catalogs

Before each auction we publish illustrated catalogs that include dates and times for previews and auctions. Our catalogs also provide descriptions and estimated values for each "lot." A lot may refer to a single item or to a group of items auctioned together. We offer our catalogs by subscription or by single copy. For information on subscribing to our catalogs, you may refer to the subscription form in this catalog, call our Client Services Department, or visit our website at [www.bonhams.com/us](http://www.bonhams.com/us).

### Previews

Auction previews are your chance to inspect each lot prior to the auction. We encourage you to look closely and examine each object on which you may want to bid so that you will know as much as possible about it. Items are sold "as is" and with all faults; illustrations in our catalogs, website and other materials are provided for identification only. At the previews, our staff is always available to answer your questions and guide you through the auction process. Condition reports may be available upon request.

### Estimates

Bonhams catalogs include estimates for each lot, exclusive of buyer's premium and tax. The estimates are provided as an approximate guide to current market value and should not be interpreted as a representation or prediction of actual selling prices. They are determined well in advance of a sale and are subject to revision. Please contact us should you have any questions about value estimates.

### Reserves

All lots in a catalog are subject to a reserve unless otherwise indicated. The reserve is the minimum price that the seller is willing to accept for a lot. This amount is confidential and does not exceed the low estimated value.

## BIDDING AT AUCTION

At Bonhams, you can bid in many ways: in person, via absentee bid, over the phone, or via Bonhams' online bidding facility. Absentee bids can be submitted in person, online, via fax or via email.

A valid Bonhams client account is required to participate in bidding activity. You can obtain registration information online, at the reception desk or by calling our Client Services Department.

By bidding at auction, whether in person or by agent, by absentee bid, telephone, online or other means, the buyer or bidder agrees to be bound by the Conditions of Sale.

Lots are auctioned in consecutive numerical order as they appear in the catalog. Bidding normally begins below the low estimate. The auctioneer will accept bids from interested parties present in the saleroom, from telephone bidders, and from absentee bidders who have left written bids in advance of the sale. The auctioneer may also execute bids on behalf of the consignor up to the amount of the reserve, but never above it.

We assume no responsibility for failure to execute bids for any reason whatsoever.

### In Person

If you are planning to bid at auction, you will need to register at the reception desk in order to receive a numbered bid card. To place a bid, hold up your card so that the auctioneer can clearly see it. Decide on the maximum amount that you wish to pay, exclusive of buyer's premium and tax, and continue bidding until your bid prevails or you reach your limit. If you are the successful bidder on a lot, the auctioneer will acknowledge your paddle number and bid amount.

### Absentee Bids

As a service to those wishing to place bids, we may at our discretion accept bids without charge in advance of sale by telephone, by facsimile or in writing on bidding forms available from us. "Buy" bids will not be accepted; all bids must state the highest bid price the bidder is willing to pay. Our auction staff will try to bid just as you would, with the goal of obtaining the

item at the lowest bid price possible. In the event identical bids are submitted, the earliest bid submitted will take precedence. Absentee bids shall be executed in competition with other absentee bids, any applicable reserve, and bids from other auction participants. A friend or agent may place bids on your behalf, provided that we have received your written authorization prior to the sale. Absentee bid forms are available in our catalogs, online at [www.bonhams.com/us](http://www.bonhams.com/us), and at our San Francisco, Los Angeles and New York galleries.

### By Telephone

Under special circumstances, we can arrange for you to bid by telephone. To arrange for a telephone bid, please contact our Client Services Department a minimum of 24 hours prior to the sale.

### Online

Web users may place absentee bids online from anywhere in the world. To bid online, please visit our website at [www.bonhams.com/us](http://www.bonhams.com/us).

We are pleased to make our live online bidding facility available to bidders in this sale.

Additional terms and conditions of sale relating to online bidding will apply. Please see [www.bonhams.com/25334](http://www.bonhams.com/25334) or contact the Client Services Department to obtain information and learn how you can register and bid online in this sale.

### Bid Increments

Bonhams generally uses the following increment multiples as bidding progresses:

\$50-200 .....	by \$10s
\$200-500 .....	by \$20/50/80s
\$500-1,000 .....	by \$50s
\$1,000-2,000 .....	by \$100s
\$2,000-5,000 .....	by \$200/500/800s
\$5,000-10,000 .....	by \$500s
\$10,000-20,000 .....	by \$1,000s
\$20,000-50,000 .....	by \$2,000/5,000/8,000s
\$50,000-100,000 .....	by \$5,000s
\$100,000-200,000 .....	by \$10,000s
above \$200,000 .....	at auctioneer's discretion

**The auctioneer may split or reject any bid at any time at his or her discretion as outlined in the Conditions of Sale.**

### Currency Converter

Solely for the convenience of bidders, a currency converter may be provided at Bonhams sales. The rates quoted for conversion of other currencies to U.S. Dollars are indications only and should not be relied upon by a bidder, and neither Bonhams nor its agents shall be responsible for any errors or omissions in the operation or accuracy of the currency converter.

### Buyer's Premium

A buyer's premium is added to the winning bid price of each individual lot purchased, at the rates set forth in the Conditions of Sale. The winning bid price plus the premium constitute the purchase price for the lot. Applicable sales taxes are computed based on this figure, and the total becomes your final purchase price.

Unless specifically illustrated and noted, fine art frames are not included in the estimate or purchase price. Bonhams accepts no liability for damage or loss to frames during storage or shipment.

All sales are final and subject to the Conditions of Sale found in our catalogs, on our website, and available at the reception desk.

### Payment

All buyers are asked to pay and pick up by 3pm on the business day following the auction. Payment may be made to Bonhams by cash, checks drawn on a U.S. bank, money order, wire transfer, or by Visa, MasterCard, American Express or Discover credit or charge card or debit card. All items must be paid for within 5 business days of the sale. Please note that payment by personal or business check may result in property not being released until purchase funds clear our bank.

### Sales Tax

Residents of states listed in Paragraph 1 of the Conditions of Sale must pay applicable sales tax. Other state or local taxes (or compensation use taxes) may apply. Sales tax will be automatically added to the invoice unless a valid resale number has been furnished or the property is shipped via common carrier to destinations outside the states listed in

the Conditions of Sale. If you wish to use your resale license please contact Cashiers for our form.

### Shipping & Removal

See page 210

Bonhams can accommodate shipping for certain items. Please contact our Cashiers Department for more information or to obtain a quote. Refer to Conditions of Sale for special terms governing the shipment of Arms and Wine. Shipments are made during weekday business hours up to four weeks after payment is received. Carriers are not permitted to deliver to P.O. Boxes.

International buyers are responsible for all import/export customs duties and taxes. An invoice stating the actual purchase price(s) will accompany all international purchases.

### Simultaneous sale property collection notice:

If this sale previews in multiple cities, please see the title page for details regarding final location of property for collection.

### Auction Results

Auction results are usually available on the next business day following the sale or online at [www.bonhams.com/us](http://www.bonhams.com/us).

# Bonhams Specialist Departments

---

## **19th Century Paintings**

London  
Charles O' Brien  
+44 20 7468 8360  
New York  
Madalina Lazen  
+1 212 644 9108

## **20th Century British Art**

London  
Matthew Bradbury  
+44 20 7468 8295

## **20th Century Fine Art**

San Francisco  
Sonja Moro  
+1 415 503 3412

## **Aboriginal Art**

Australia  
Francesca Cavazzini  
+61 2 8412 2222

## **African, Oceanic & Pre-Columbian Art**

Los Angeles  
Fredric W. Backlar  
+1 323 436 5416 •

## **American Paintings**

New York  
Jennifer Jacobsen  
+1 917 206 1699

## **Antiquities**

London  
Francesca Hickin  
+44 20 7468 8226

## **Antique Arms & Armour**

London  
David Williams  
+44 20 7393 3807

## **Art Collections, Estates & Valuations**

London  
Harvey Cammell  
+44 (0) 20 7468 8340  
New York  
Sherri Cohen  
+1 917 206 1671  
Los Angeles  
Leslie Wright  
+1 323 436 5408  
Joseph Francaviglia  
+1 323 436 5443  
Lydia Ganley  
+1 323 436 4496  
San Francisco  
Victoria Richardson  
+1 415 503 3207  
Celeste Smith  
+1 415 503 3214

## **Australian Art**

Australia  
Merryn Schriever  
+61 2 8412 2222  
Alex Clark  
+61 3 8640 4088

## **Australian Colonial Furniture and Australiana**

+61 2 8412 2222

## **Books, Maps & Manuscripts**

London  
Matthew Haley  
+44 20 7393 3817  
New York  
Ian Ehling  
+1 212 644 9094  
Darren Sutherland  
+1 212 461 6531  
Los Angeles  
Catherine Williamson  
+1 323 436 5442  
San Francisco  
Adam Stackhouse  
+1 415 503 3266

## **British & European Glass**

London  
John Sandon  
+44 20 7468 8244

## **British Ceramics**

London  
John Sandon  
+44 20 7468 8244

## **California & Western Paintings & Sculpture**

Los Angeles  
Scot Levitt  
+1 323 436 5425  
Kathy Wong  
+1 323 436 5415  
San Francisco  
Aaron Bastian  
+1 415 503 3241

## **Carpets**

London  
Helena Gumley-Mason  
+44 20 8393 2615

## **Chinese & Asian Art**

London  
Asaph Hyman  
+44 20 7468 5888  
New York  
Bruce MacLaren,  
+1 917 206 1677  
Ming Hua  
+1 646 837 8132  
Harold Yeo  
+1 917 206 1628 •  
Los Angeles  
Rachel Du  
+1 323 436 5587  
San Francisco  
Dessa Goddard  
+1 415 503 3333  
Henry Kleinhenz  
+1 415 503 3336  
Daniel Hersklee  
+1 415 503 3271  
Lingling Shang  
+1 415 503 3207 •  
Amelia Chao  
+1 415 503 3397  
Hong Kong  
Xibo Wang,  
+852 3607 0010  
Australia  
Yvett Klein,  
+61 2 8412 2231

## **Chinese Paintings**

Hong Kong  
Iris Miao,  
+852 3607 0011

## **Clocks**

London  
James Stratton  
+44 20 7468 8364  
New York  
Jonathan Snellenburg  
+1 212 461 6530

## **Coins & Medals**

London  
John Millensted  
+44 20 7393 3914  
Los Angeles  
Paul Song  
+1 323 436 5455

## **Entertainment**

Memorabilia  
London  
Katherine Schofield  
+44 20 7393 3871  
Los Angeles  
Catherine Williamson  
+1 323 436 5442  
Dana Hawkes  
+1 978 283 1518

## **European Ceramics**

London  
Sebastian Kuhn  
+44 20 7468 8384

## **European Paintings**

London  
Charles O' Brien  
+44 20 7468 8360  
New York  
Madalina Lazen  
+1 212 644 9108  
Los Angeles  
Mark Fisher  
+1 323 436 5488  
Rocco Rich  
+1 323 436 5410

## **European Sculptures & Works of Art**

London  
Michael Lake  
+44 20 8963 6813

## **Furniture and Decorative Art**

London  
Thomas Moore  
+44 20 8963 2816  
Los Angeles  
Angela Past  
+1 323 436 5422  
Anna Hicks  
+1 323 436 5463

## **Greek Art**

London  
Anastasia Orfanidou  
+44 20 7468 8356

## **Golf Sporting Memorabilia**

Edinburgh  
Kevin McGimpsey  
+44 131 240 2296  
Hamish Wilson  
+44 131 240 0916

## **Irish Art**

London  
Penny Day  
+44 20 7468 8366

## **Impressionist & Modern Art**

London  
India Phillips  
+44 20 7468 8328  
New York  
Caitlyn Pickens  
+1 212 644 9135  
Los Angeles  
Kathy Wong  
+1 323 436 5415

## **Indian, Himalayan & Southeast Asian Art**

New York  
Mark Rasmussen  
+1 917 206 1688  
Hong Kong  
Edward Wilkinson  
+852 2918 4321

## **Islamic & Indian Art**

London  
Oliver White  
+44 20 7468 8303

## **Japanese Art**

London  
Suzannah Yip  
+44 20 7468 8368  
New York  
Jeff Olson  
+1 212 461 6516

## **Jewellery**

London  
Jean Ghika  
+44 20 7468 8282  
Emily Barber  
+44 20 7468 8284  
New York  
Brett O'Connor  
+1 212 461 6525  
Caroline Morrissey  
+1 212 644 9046  
Camille Barbier  
+1 212 644 9035  
Los Angeles  
Dana Ehrman  
+1 323 436 5407  
Emily Waterfall  
+1 323 436 5426  
San Francisco  
Shannon Beck  
+1 415 503 3306  
Hong Kong  
Paul Redmayne  
+852 3607 0006

## **Marine Art**

London  
Veronique Scorer  
+44 20 7393 3962

**Mechanical Music  
London**

Jon Baddeley  
+44 20 7393 3872

**Modern & Contemporary  
African Art**

**London**  
Giles Peppiatt  
+ 44 20 7468 8355

**New York**  
Hayley Grundy  
+1 917 206 1624

**Modern & Contemporary  
Middle Eastern Art**

**London**  
Nima Sagharchi  
+44 20 7468 8342

**Modern & Contemporary  
South Asian Art**

**London**  
Tahmina Ghaffar  
+44 207 468 8382

**Modern Decorative  
Art + Design**

**London**  
Mark Oliver  
+44 20 7393 3856

**New York**  
Benjamin Walker  
+1 212 710 1306  
Dan Tolson  
+1 917 206 1611

**Los Angeles**  
Jason Stein  
+1 323 436 5466

**Motor Cars  
London**

Tim Schofield  
+44 20 7468 5804

**New York**  
Rupert Banner  
+1 212 461 6515  
Eric Minoff  
+1 917 206 1630  
Evan Ide  
+1 917 340 4657

**Los Angeles**  
Jakob Greisen  
+1 415 503 3284  
Michael Caimano  
+1 929 666 2243

**San Francisco**  
Mark Osborne  
+1 415 503 3353

**Europe**  
Philip Kantor  
+32 476 879 471

**Automobilia  
London**

Toby Wilson  
+44 20 8963 2842  
Adrian Pipiros  
+44 20 8963 2840

**Motorcycles  
London**

Ben Walker  
+44 20 8963 2819  
James Stensel  
+44 20 8963 2818  
**Los Angeles**  
Craig Mallery  
+1 323 436 5470

**Museum Services  
San Francisco**

Laura King Pfaff  
+1 415 503 3210

**Native American Art  
San Francisco**

Ingmars Lindbergs  
+1 415 503 3393

**Natural History  
Los Angeles**

Claudia Florian  
+1 323 436 5437  
+1 310 469 8567 •  
Thomas E. Lindgren  
+1 310 469 8567 •

**Old Master Pictures  
London**

Andrew Mckenzie  
+44 20 7468 8261  
**Los Angeles**  
Mark Fisher  
+1 323 436 5488

**Orientalist Art  
London**

Charles O'Brien  
+44 20 7468 8360

**Photography  
New York**

Laura Paterson  
+1 917 206 1653  
**Los Angeles & San Francisco**  
Morisa Rosenberg  
+1 323 436 5435  
+1 415 503 3259

**Post-War and  
Contemporary Art  
London**

Ralph Taylor  
+44 20 7447 7403

**New York**  
Muys Sniijders,  
+ 212 644 9020  
Jeremy Goldsmith,  
+ 1 917 206 1656  
Jacqueline Towers-Perkins,  
+1 212 644 9039  
Lisa De Simone,  
+1 917 206 1607

**Los Angeles**  
Sharon Squires  
+1 323 436 5404  
Laura Bjorstad  
+1 323 436 5446

**Prints and Multiples  
London**

Lucia Tro Santafe  
+44 20 7468 8262

**New York**  
Deborah Ripley  
+1 212 644 9059

**Los Angeles**  
Morisa Rosenberg  
+1 323 447 9374

**Russian Art  
London**

Daria Khristova  
+44 20 7468 8334

**New York**  
Yelena Harbick  
+1 212 644 9136

**Scientific Instruments  
London**

Jon Baddeley  
+44 20 7393 3872  
**New York**  
Jonathan Snellenburg  
+1 212 461 6530

**Scottish Pictures  
Edinburgh**

Chris Brickley  
+44 131 240 2297

**Silver & Gold Boxes  
London**

Ellis Finch  
+44 20 7393 3973

**Sporting Guns  
London**

Patrick Hawes  
+44 20 7393 3815

**Space History  
San Francisco**

Adam Stackhouse  
+1 415 503 3266

**Travel Pictures  
London**

Veronique Scorer  
+44 20 7393 3962

**Watches &  
Wristwatches  
London**

Jonathan Darracott  
+44 20 7447 7412

**New York**  
Jonathan Snellenburg  
+1 212 461 6530

**Hong Kong**  
Tim Bourne  
+852 3607 0021

**Whisky**

**Edinburgh**  
Martin Green  
+44 131 225 2266

**Hong Kong**  
Daniel Lam  
+852 2918 4321

**Wine  
London**

Richard Harvey  
+44 20 7468 5811

**San Francisco**  
Christine Ballard  
+1 415 503 3221

**Hong Kong**  
Daniel Lam  
+852 2918 4321

**Client Services Departments**

**U.S.A.**

**San Francisco**  
(415) 861 7500  
(415) 861 8951 fax  
Monday - Friday, 9am to 5pm

**Los Angeles**

(323) 850 7500  
(323) 850 6090 fax  
Monday - Friday, 9am to 5pm

**New York**

(212) 644 9001  
(212) 644 9009 fax  
Monday - Friday, 9am to 5pm

**Toll Free**

(800) 223 2854

**U.K.**

Monday to Friday 8.30 to 6.00  
+44 (0) 20 7447 7447

**Bids**

+44 (0) 20 7447 7447  
+44 (0) 20 7447 7401 fax  
To bid via the internet please  
visit [bonhams.com](http://bonhams.com)

• Indicates independent contractor

# Bonhams Global Network

---

## International Salerooms

**London**  
101 New Bond Street  
London W1S 1SR  
+44 20 7447 7447  
+44 20 7447 7400 fax

**New York**  
580 Madison Avenue  
New York, NY  
10022  
+1 (212) 644 9001  
+1 (212) 644 9007 fax

**Hong Kong**  
Suite 2001  
One Pacific Place  
88 Queensway  
Admiralty  
Hong Kong  
+852 2918 4321  
+852 2918 4320 fax

**London**  
Montpelier Street London  
SW7 1HH  
+44 20 7393 3900  
+44 20 7393 3905 fax

---

## Offices and Associated Companies

### AFRICA

**Nigeria**  
Neil Coventry  
+234 (0)8110 033 792  
+27 (0)7611 20171  
neil.coventry@bonhams.com

**South Africa - Johannesburg**  
Penny Culverwell  
+27 (0)71 342 2670  
penny.culverwell@bonhams.com

### AUSTRALIA

**Sydney**  
97-99 Queen Street,  
Woollahra, NSW 2025  
Australia  
+61 (0) 2 8412 2222  
+61 (0) 2 9475 4110 fax  
info.aus@bonhams.com

**Melbourne**  
Como House  
Como Avenue  
South Yarra  
Melbourne VIC 3141  
Australia  
+61 (0) 3 8640 4088  
+61 (0) 2 9475 4110 fax  
info.aus@bonhams.com

### ASIA

**Beijing**  
Jessica Zhang  
Unit S102A, Beijing  
Lufthansa Center,  
50 Liangmaqiao Road,  
Chaoyang District,  
Beijing 100125, China  
+86 (0) 10 8424 3188  
beijing@bonhams.com

**Singapore**  
Bernadette Rankine  
11th Floor, Wisma Atria  
435 Orchard Road  
Singapore 238877  
+65 (0) 6701 8038  
+65 (0) 6701 8001 fax  
bernadette.rankine@bonhams.com

**Taiwan**  
37th Floor, Taipei 101  
Tower  
No. 7 Xinyi Road,  
Section 5  
Taipei, 100  
+886 2 8758 2898  
+886 2 8758 2897 fax  
taiwan@bonhams.com

### EUROPE

**Austria**  
Thomas Kamm  
+49 (0) 89 2420 5812  
austria@bonhams.com

**Belgium**  
Boulevard  
Saint-Michel 101  
1040 Brussels  
+32 (0) 2 736 5076  
belgium@bonhams.com

**France**  
4 rue de la Paix  
75002 Paris  
+33 (0) 1 42 61 10 10  
paris@bonhams.com

**Germany - Cologne**  
Katharina Schmid  
+49 (0) 221 9865 3419  
+49 (0) 157 9234 6717  
cologne@bonhams.com

**Germany - Hamburg**  
Marie Becker Lingenthal  
+49 (0) 17 4236 0022  
hamburg@bonhams.com

**Germany - Munich**  
Maximilianstrasse 52  
80538 Munich  
+49 (0) 89 2420 5812  
munich@bonhams.com

**Germany - Stuttgart**  
Neue Brücke 2  
New Bridge Offices  
70173 Stuttgart  
+49 (0) 711 2195 2640  
+49 (0) 157 9234 6717  
stuttgart@bonhams.com

**Greece**  
7 Neofytou Vamva  
Street  
Athens 10674  
+30 (0) 210 3636 404  
athens@bonhams.com

**Ireland**  
31 Molesworth Street  
Dublin 2  
+353 (0) 1 602 0990  
ireland@bonhams.com

**Italy - Milan**  
Via Boccaccio 22  
20123 Milano  
+39 0 2 4953 9020  
milan@bonhams.com

**Italy - Rome**  
Via Sicilia 50  
00187 Roma  
+39 06 485 900  
rome@bonhams.com

**The Netherlands**  
De Lairessestraat 154  
1075 HL Amsterdam  
+31 (0) 20 67 09 701  
amsterdam@bonhams.com

**Portugal**  
Rua Bartolomeu Dias  
nº160. 1º  
Belem  
1400-031 Lisbon  
+351 218 293 291  
portugal@bonhams.com

**Spain - Barcelona**  
Teresa Ybarra  
+34 930 156 686  
+34 680 347 606  
barcelona@bonhams.com

**Spain - Madrid**  
Núñez de Balboa no  
4-1C  
28001 Madrid  
+34 915 78 17 27  
madrid@bonhams.com

**Switzerland - Geneva**  
Rue Etienne-Dumont 10  
1204 Geneva  
+41 (0) 22 300 3160  
geneva@bonhams.com

**Switzerland - Zurich**  
Andrea Bodmer  
Dreikönigstrasse 31a  
8002 Zürich  
+41 44 281 9535  
zurich@bonhams.com

### NORTH AMERICA

**USA**  
Representatives:  
**Arizona**  
Terri Adrian-Hardy  
+1 (602) 859 1843  
arizona@bonhams.com

**California Central Valley**  
David Daniel  
+1 (916) 364 1645  
sacramento@bonhams.com

**California Palm Springs**  
Brooke Sivo  
+1 (760) 350 4255  
palmsprings@bonhams.com

**California San Diego**  
Brooke Sivo  
+1 (760) 567 1744  
sandiego@bonhams.com

**Colorado**  
Lance Vigil  
+1 (720) 355 3737  
colorado@bonhams.com

**Florida**  
April Matteini  
+1 (305) 978 2459  
Miami@bonhams.com  
Alexis Butler  
+1 (305) 878 5366  
Miami@bonhams.com

**Georgia**  
Mary Moore Bethea  
+1 (404) 842 1500  
georgia@bonhams.com

**Illinois & Midwest**  
Natalie B. Waechter  
+1 (773) 267 3300  
Shawn Marsh  
+1 (773) 680 2881  
chicago@bonhams.com

---

**Edinburgh**

22 Queen Street  
Edinburgh  
EH2 1JX  
+44 131 225 2266  
+44 131 220 2547 fax

**Los Angeles**

7601 W. Sunset Boulevard  
Los Angeles  
CA 90046  
+1 (323) 850 7500  
+1 (323) 850 6090 fax

**San Francisco**

220 San Bruno Avenue  
San Francisco  
CA 94103  
+1 (415) 861 7500  
+1 (415) 861 8951 fax

---

**UNITED KINGDOM****Massachusetts**

Amy Corcoran  
+1 (617) 742 0909  
boston@bonhams.com

**Nevada**

David Daniel  
+1 (775) 831 0330  
nevada@bonhams.com

**New Mexico**

Terri Adrian-Hardy  
+1 (602) 859 1843  
newmexico@bonhams.com

**Oregon**

Sheryl Acheson  
+1 (971) 727 7797  
oregon@bonhams.com

**Texas – Dallas**

Mary Holm  
+1 (214) 557 2716  
dallas@bonhams.com

**Texas – Houston**

Lindsay Davis  
+1 (713) 855 7452  
texas@bonhams.com

**Virginia**

Gertraud Hechl  
+1 (202) 422 2733  
virginia@bonhams.com

**Washington**

Heather O'Mahony  
+1 (206) 566 3913  
seattle@bonhams.com

**Washington DC  
Mid-Atlantic Region**

Gertraud Hechl  
+1 (202) 422 2733  
washingtonDC@bonhams.com

**Canada****Toronto, Ontario**

Kristin Kearney  
340 King St East  
2nd Floor, Office 213  
Toronto ON  
M5A 1K8  
+1 (416) 462 9004  
info.ca@bonhams.com

**Montreal, Quebec**

David Kelsey  
+1 (514) 894 1138  
info.ca@bonhams.com

**MIDDLE EAST****Israel**

Joslyne Halibard  
+972 (0)54 553 5337  
joslyne.halibard@bonhams.com

**SOUTH AMERICA****Brazil**

+55 11 3031 4444  
+55 11 3031 4444  
fax

**South East England****Guildford**

Millmead,  
Guildford,  
Surrey GU2 4BE  
+44 1483 504 030  
+44 1483 450 205  
fax

**Isle of Wight**

+44 1273 220 000

Representative:

**Brighton & Hove**

Tim Squire-Sanders  
+44 1273 220 000

**West Sussex**

+44 (0) 1273 220 000

**South West England****Bath**

Queen Square House  
Charlotte Street  
Bath BA1 2LL  
+44 1225 788 988  
+44 1225 446 675  
fax

**Cornwall – Truro**

36 Lemon Street  
Truro  
Cornwall  
TR1 2NR  
+44 1872 250 170  
+44 1872 250 179  
fax

**Exeter**

The Lodge  
Southernhay West  
Exeter, Devon  
EX1 1JG  
+44 1392 425 264  
+44 1392 494 561  
fax

**Tetbury**

Eight Bells House  
14 Church Street  
Tetbury  
Gloucestershire  
GL8 8JG  
+44 1666 502 200  
+44 1666 505 107  
fax

Representatives:

**Dorset**

Bill Allan  
+44 1935 815 271

**East Anglia and Bury St. Edmunds**

Michael Steel  
+44 1284 716 190

**Norfolk**

The Market Place  
Reepham  
Norfolk NR10 4JJ  
+44 1603 871 443  
+44 1603 872 973  
fax

**Midlands****Knowle**

The Old House  
Station Road  
Knowle, Solihull  
West Midlands  
B93 0HT  
+44 1564 776 151  
+44 1564 778 069  
fax

**Oxford**

Banbury Road  
Shipton on Cherwell  
Kidlington OX5 1JH  
+44 1865 853 640  
+44 1865 372 722  
fax

**Yorkshire & North East England****Leeds**

The West Wing  
Bowcliffe Hall  
Bramham  
Leeds  
LS23 6LP  
+44 113 234 5755  
+44 113 244 3910  
fax

**North West England****Chester**

2 St Johns Court,  
Vicars Lane,  
Chester,  
CH1 1QE  
+44 1244 313 936  
+44 1244 340 028  
fax

**Manchester**

The Stables  
213 Ashley Road  
Hale WA15 9TB  
+44 161 927 3822  
+44 161 927 3824  
fax

**Channel Islands****Jersey**

La Chasse  
La Rue de la Vallee  
St Mary  
Jersey JE3 3DL  
+44 1534 722 441  
+44 1534 759 354  
fax

Representative:

**Guernsey**

+44 1481 722 448

**Scotland****Bonhams West of Scotland**

Kirkhill House  
Broom Road East  
Newton Mearns  
Glasgow  
G77 5LL  
+44 141 223 8866

**Wales**

Representatives:

**Cardiff**

Jeff Muse  
+44 2920 727 980



# Auction Registration Form

(Attendee / Absentee / Online / Telephone Bidding)

Please circle your bidding method above.

--	--	--	--

**Paddle number (for office use only)**

**General Notice:** This sale will be conducted in accordance with Bonhams Conditions of Sale, and your bidding and buying at the sale will be governed by such terms and conditions. Please read the Conditions of Sale in conjunction with the Buyer's Guide relating to this sale and other published notices and terms relating to bidding. Payment by personal or business check may result in your property not being released until purchase funds clear our bank. Checks must be drawn on a U.S. bank.

**Notice to Absentee Bidders:** In the table below, please provide details of the lots on which you wish to place bids at least 24 hours prior to the sale. Bids will be rounded down to the nearest increment. Please refer to the Buyer's Guide in the catalog for further information relating to instructions to Bonhams to execute absentee bids on your behalf. Bonhams will endeavor to execute bids on your behalf but will not be liable for any errors or non-executed bids.

**Notice to First Time Bidders:** New clients are requested to provide photographic proof of ID - passport, driving license, ID card, together with proof of address - utility bill, bank or credit card statement etc. Corporate clients should also provide a copy of their articles of association / company registration documents, together with a letter authorizing the individual to bid on the company's behalf. Failure to provide this may result in your bids not being processed. For higher value lots you may also be asked to provide a bankers reference.

**Notice to online bidders:** If you have forgotten your username and password for [www.bonhams.com](http://www.bonhams.com), please contact Client Services.

**If successful**

- I will collect the purchases myself
- Please contact me with a shipping quote (if applicable)
- I will arrange a third party to collect my purchase(s)

**Please email or fax the completed Registration Form and requested information to:**

Bonhams Client Services Department  
7601 W. Sunset Blvd  
Los Angeles, California 90046  
Tel +1 (323) 850 7500  
Fax +1 (323) 850 6090  
bids.us@bonhams.com

# Bonhams

Sale title: Modern Design   Art		Sale date: Wednesday April 24, 2019	
Sale no. 25334		Sale venue: Los Angeles	
<b>General Bid Increments:</b>			
\$10 - 200 .....by 10s		\$10,000 - 20,000 .....by 1,000s	
\$200 - 500 .....by 20 / 50 / 80s		\$20,000 - 50,000 .....by 2,000 / 5,000 / 8,000s	
\$500 - 1,000 .....by 50s		\$50,000 - 100,000 .....by 5,000s	
\$1,000 - 2,000 .....by 100s		\$100,000 - 200,000 .....by 10,000s	
\$2,000 - 5,000 .....by 200 / 500 / 800s		above \$200,000 .....at the auctioneer's discretion	
\$5,000 - 10,000 .....by 500s		The auctioneer has discretion to split any bid at any time.	
Customer Number		Title	
First Name		Last Name	
Company name (to be invoiced if applicable)			
Address			
City		County / State	
Post / Zip code		Country	
Telephone mobile		Telephone daytime	
Telephone evening		Fax	
Telephone bidders: indicate primary and secondary contact numbers by writing ① or ② next to the telephone number.			
E-mail (in capitals) _____			
By providing your email address above, you authorize Bonhams to send you marketing materials and news concerning Bonhams and partner organizations. Bonhams does not sell or trade email addresses.			
I am registering to bid as a private client <input type="checkbox"/>		I am registering to bid as a trade client <input type="checkbox"/>	
Resale: please enter your resale license number here _____ We may contact you for additional information.			

SHIPPING	
Shipping Address (if different than above):	
Address: _____	Country: _____
City: _____	Post/ZIP code: _____

**Please note that all telephone calls are recorded.**

Type of bid (A-Absentee, T-Telephone)	Lot no.	Brief description (In the event of any discrepancy, lot number and not lot description will govern.) If you are bidding online there is no need to complete this section.	MAX bid in US\$ (excluding premium and applicable tax) Emergency bid for telephone bidders only*

**You instruct us to execute each absentee bid up to the corresponding bid amount indicated above.**

\* Emergency Bid: A maximum bid (exclusive of Buyer's Premium and tax) to be executed by Bonhams only if we are unable to contact you by telephone or should the connection be lost during bidding.

BY SIGNING THIS FORM YOU AGREE THAT YOU HAVE READ AND UNDERSTAND OUR CONDITIONS OF SALE AND SHALL BE LEGALLY BOUND BY THEM, AND YOU AGREE TO PAY THE BUYER'S PREMIUM, ANY APPLICABLE TAXES, AND ANY OTHER CHARGES MENTIONED IN THE BUYER'S GUIDE OR CONDITIONS OF SALE. THIS AFFECTS YOUR LEGAL RIGHTS.	
Your signature: _____	Date: _____

# Index

- A**  
Albertus, Gundorph 214  
Amphora 50  
Andersen, Gunnar Aagaard 333  
Andre Mare, Louis Süe and  
Autio, Rudy 92  
353
- B**  
Bacci, Edmondo 178  
Baughman, Milo 182  
BBPR, Studio 318  
Beaumont, Hanneke 337  
Benney, Gerald Sallis 331  
Benton, Fletcher 328  
Berthoud, Paul-Francois 44  
Bertoia, Val 298  
Bianconi, Fulvio 276  
Blanchard, Porter 327  
Block, Roberto and Mito 89  
Blondat, Max 43  
Bolotowsky, Ilya 325  
Borsani, Osvaldo 252, 253, 299  
Brandt, Edgar-William 83  
Brazier-Jones, Mark 341  
Brychtová, Stanislav Libenský/Jaroslava 388  
Bubacco, Lucio 376  
Bufano, Benjamin 196, 197  
Buffa, Paolo 150
- C**  
Callas, Peter 356  
Capron, Roger 167, 194  
Castle, Wendell 339  
Chihuly, Dale 379, 380, 381  
Conover, Luther 201  
Csaky, Joseph 95
- D**  
Delisle, Roseline 346  
Derain, André 220  
Deskey, Donald 96  
Dubreuil, Andre 334  
Duckworth, Ruth 355  
Dudouyt, Charles 74, 76  
Duquette, Tony 225, 227, 228
- E**  
Eames, Charles & Ray 157, 158, 160, 161  
Eek Hein, Piet 314  
Ellis, Harvey 20  
Ernst, George 293, 295  
Etrog, Sorel 221
- F**  
Faraone 332  
Ferguson, Kenneth 352  
Frankl, Paul T. 99  
Friedeberg, Pedro 177
- G**  
Gallé, Émile 45, 46, 49, 69  
Gambone, Bruno 169  
Graham, Robert 208  
Gray, Cleve 149  
Greco, Emilio 285  
Greene & Greene 21
- H**  
Hadzi, Dimitri 186  
Haines, William 226
- J**  
Jensen, Georg 80, 189, 210, 211, 213, 216, 217  
Johnson, Dan 163  
Juhl, Finn 155, 188
- K**  
Kagan, Vladimir 300, 301, 303, 304, 309  
Knox, Archibald 19  
Kohlmeyer, Ida Rittenberg 317, 319
- L**  
Laing, Gerald 324  
Lalique, Marc 59, 60  
Lalique, René 57, 58, 61, 62, 63, 64, 65, 68, 86  
Lamb, Walter 162, 165  
Laszlo, Paul 146  
Laverne, Philip and Kelvin 267, 283, 287  
Leach, Bernard 361  
Leach, David 362
- Léonard, Agathon 41  
Lieberman, Alexander 98  
Liberty & Co. 17  
Lipofsky, Marvin 383  
Lovet-Lorski, Boris 88  
Lucero, Michael 348
- M**  
Man Ray 316  
Mangiarotti, Angelo 312  
Mariani, Umberto 257  
Martinez, Ricardo 206  
Mathsson, Bruno 313, 315  
Mogensen, Borge 193  
Moroles, Jesús Bautista 340  
Morris, William C. 335, 386  
Mouille, Serge 205  
Moulthrop, Philip 191
- N**  
Nakashima, George 173  
Nancy, Daum 48, 52, 53, 56, 81  
Nelson, George Laurence 258  
Nielsen, Harald 215  
Norell, Arne 175
- O**  
Ollitski, Jules 145
- P**  
Pani, Arturo 97, 179, 180, 181  
Parzinger, Tommi 279, 280  
Pascaud, Jean 78  
Pavlik, Michael 374  
Perkins, Danny 378  
Pesce, Gaetano 296, 342  
Picasso, Pablo 164  
Platner, Warren 203, 204  
Pomodoro, Arnaldo 168  
Ponti and Turchini 199  
Ponti, Gio 151  
Poray, Stan P. 73  
Puiforcat, Jean E. 75, 77
- Q**  
Quinet, Jacques 271
- R**  
Rady, Elsa 347  
Reitz, Don 357  
Rojas, Rolando 288  
Rookwood Pottery 13, 14  
Ruhlmann, Emile Jacques 93
- S**  
Saarinen, Eero 272, 273, 274  
Saarinen, Eliel 375  
Santillana, Laura de 387  
Scheier, Edwin 176  
Schwarcz, June 190  
Serrano, Pablo 219  
Seyle, Robert 222  
Shire, Peter 344, 345  
Soldner, Paul 358  
Springer, Karl 289  
Steuben 67  
Stickley, Gustav 25
- T**  
Tiffany Studios 27, 30, 31, 33, 38, 40  
Tura, Aldo 170, 281
- V**  
Van der Straeten, Hervé 343  
van Erp, Dirk 16  
Velizar Mihich, Vasa 322, 323  
Venini 277  
Vernard, Claude 172
- W**  
Wegner, Hans J. 152, 153  
Weinberg, Steven 369, 370, 371  
Wildenhain, Marguerite 365, 366, 367, 368  
Wood, Beatrice 349, 350  
Wright, Frank Lloyd 209
- Z**  
Zynsky, Mary Ann (Toots) 382



# Bonhams

AUCTIONEERS SINCE 1793

## American Art

New York | May 22, 2019

### INQUIRIES

Jennifer Jacobsen  
+1 212 710 1307  
jennifer.jacobsen@bonhams.com  
bonhams.com/americanart

### CHARLES E. PRENDERGAST (1863-1948)

*Fantasy* (detail)  
signed 'C. Prendergast'  
tempera and gold leaf and pencil  
on gessoed panel, 23 x 31in  
Painted circa 1916-18.  
**\$200,000 - 300,000**







**Bonhams**  
7601 W. Sunset Boulevard  
Los Angeles CA 90046

---

+1 323 850 7500  
bonhams.com

**AUCTIONEERS SINCE 1793**